



aerospace  
climate control  
electromechanical  
filtration  
fluid & gas handling  
**hydraulics**  
pneumatics  
process control  
sealing & shielding



# Oil Coolers For Temperature Optimization In Hydraulic Systems

Catalog HY10-1700/Americas



ENGINEERING YOUR SUCCESS.



If you have questions about the products contained in this catalog, or their applications, please contact:



**Accumulator & Cooler  
Division - Americas**  
phone **815 636 4100**  
fax **815 636 4111**  
**[parker.com/accumulator](http://parker.com/accumulator)**

Extra care is taken in the preparation of this literature, but Parker is not responsible for any inadvertent typographical errors or omissions. Information in this catalog is only accurate as of the date of publication. For a more current information base, please consult the Parker Accumulator Division web site at **[parker.com/accumulator](http://parker.com/accumulator)**.

### Offer of Sale

The items described in this document are hereby offered for sale by Parker Hannifin Corporation, its subsidiaries or its authorized distributors. This offer and its acceptance are governed by the provisions in the **“Offer of Sale.”**

**NOTE:** Failure or improper selection or improper use of coolers or related items can cause death, personal injury and property damage. Parker Hannifin shall not be liable for any incidental, consequential or special damages that result from use of the information contained in this publication.

### **WARNING**

**FAILURE OR IMPROPER SELECTION OR IMPROPER USE OF THE PRODUCTS AND/OR SYSTEMS DESCRIBED HEREIN OR RELATED ITEMS CAN CAUSE DEATH, PERSONAL INJURY AND PROPERTY DAMAGE.**

This document and other information from Parker Hannifin Corporation, its subsidiaries and authorized distributors provide product and/or system options for further investigation by users having expertise. It is important that you analyze all aspects of your application, including consequences of any failure and review the information concerning the product or system in the current product catalog. Due to the variety of operating conditions and applications for these products or systems, the user, through its own analysis and testing, is solely responsible for making the final selection of the products and systems and assuring that all performance, safety and warning requirements of the application are met.

The products described herein, including without limitation, product features, specifications, designs, availability and pricing, are subject to change by Parker Hannifin Corporation and its related companies at any time without notice.

# Table of Contents

<b>Oil Coolers</b> .....	<b>4</b>
<b>More Cooling Per \$</b> .....	<b>6</b>
<b>ULAC With AC Motor</b> .....	<b>9</b>
Cooling Performance .....	10
Pressure Drop.....	11
Dimensions.....	12
Order Key and Technical Specifications.....	14
<b>ULOC Cooling System</b> .....	<b>15</b>
Cooling Performance .....	16
Dimensions.....	17
Order Key and Technical Specifications.....	18
<b>ULDC With DC Motor</b> .....	<b>19</b>
Cooling Performance .....	20
Pressure Drop.....	20
Dimensions.....	21
Order Key and Technical Specifications.....	22
<b>ULHC With Hydraulic Motor</b> .....	<b>23</b>
Cooling Performance .....	24
Pressure Drop.....	25
Dimensions.....	26
Order Key and Technical Specifications.....	28
<b>OAW Cooling System</b> .....	<b>29</b>
General.....	30
Cooling Performance, Pressure Drop, Dimensions .....	31
Installation.....	34
<b>Accessories</b> .....	<b>37</b>
<b>Cooling Modules/Combination Cooler</b> .....	<b>38</b>
<b>Product Groups</b> .....	<b>39</b>





Parker is a global player specializing in innovative, efficient system solutions for temperature optimization and energy storage. All over the world, our products are working in the most diverse environments and applications.

# Oil Coolers

Choosing the right cooler requires precise system sizing. The most reliable way to size a cooler is with the aid of our calculation program. This program, together with precise evaluations from our experienced, skilled engineers, gives you the opportunity for more cooling per \$ invested.

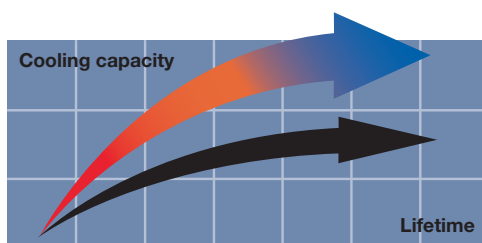

## Overheating – an expensive problem

An underestimated cooling capacity produces a temperature that is too high. The consequences are poor lubricating properties, higher internal leakage, a higher risk of cavitation, damaged components, etc. Overheating leads to a significant drop in efficiency which can be detrimental to our environment.

## Temperature optimization – a basic prerequisite for cost-efficient operation

Temperature balance in a hydraulic system occurs when the cooler can cool down the energy input that the system does not consume – the system's lost energy ( $P_{loss} = P_{cool} = P_{in} - P_{used}$ ).

Temperature optimization occurs at the temperature at which the oil viscosity is maintained at

recommended values. The correct working temperature produces a number of economic and environmental benefits:

- The hydraulic system's useful life is extended.
- The oil's useful life is extended.
- The hydraulic system's availability increases – more operating time and fewer shutdowns.
- Service and repair costs are reduced.
- High efficiency level maintained in continuous operation – the system's efficiency falls if the temperature exceeds the ideal working temperature.



## ULAC with AC Motor

For industrial use – maximum cooling capacity 400 HP\*

**Optimized design** with the right choice of materials and components ensures reliable and long lasting cooling with low service and maintenance costs.

**Compact design** results in a lighter weight unit with higher cooling capacity and lower pressure drop.

**Easy to maintain** and easy to retrofit into many applications.

**Quiet fan design** due to optimization of material and blade.

**AC motor** – NEMA three phase motors are standard. A wide range of operating voltages and frequencies available.

**Cooler core** with low pressure drop and high cooling capacity.



## ULOC Cooling System

For industrial use – maximum cooling capacity 60 HP

**Optimized design** and the right choice of materials and components produce a long useful life, high availability and low service and maintenance costs.

**Integrated** circulation pump produces an even flow with low pressure pulsations.

**Easy to maintain** and easy to retrofit in many applications.

**Compact design** and low weight.

**Quiet fan** and pump.

**Cooler core** with low pressure drop and high cooling capacity.



## ULDC with DC Motor

For mobile use – maximum cooling capacity 40 HP

**Optimized design** with the right choice of materials and components ensures reliable and long lasting cooling with low service and maintenance costs.

**Compact design** results in a lighter weight unit with higher cooling capacity and lower pressure drop.

**Easy to maintain** and easy to retrofit into many applications.

**DC motor** 12V/24V

**Quiet fan** and fan motor.



## ULHC with Hydraulic Motor

For mobile and industrial use – maximum cooling capacity 215 HP

**Optimized design** and the right choice of materials and components produce a long useful life, high availability and low service and maintenance costs.

**Compact design** results in a lighter weight unit with higher cooling capacity and lower pressure drop.

**Easy to maintain** and easy to retrofit into many applications.

**Hydraulic motor** with displacement from 8.4 cc/rev to 25.2 cc/rev.

**Collar bearing** for fan motor on larger models provides longer operating life.

**Quiet fan design** due to optimization of material and blade.

**Cooler core** with low pressure drop and high cooling capacity.



## OAW Cooling System

For mobile and industrial use – maximum cooling capacity 274 HP

**Optimized design** and the right choice of materials and components ensures reliable and long lasting cooling with low service and maintenance costs.

**Compact design** for easy installation.

**Turbulent water flow** prevents clogging and reduces maintenance.

**Low water consumption** for economical operation.

**SAE O-ring connections** for ease of assembly and leak-proof operation.

**Maximum material efficiency** with no "Dead Zone" outside gaskets.



\*At 250 gpm and 70 °F ITD

# More Cooling Per \$

with precise calculations and our engineers' support

## **Optimal sizing produces efficient cooling.**

Correct sizing requires knowledge and experience. Our calculation program, combined with our engineers' support, gives you access to this very knowledge and experience. The result is more cooling per \$ invested.

## **In-depth system review as an added value.**

A more wide-ranging review of the hydraulic system is often a natural element of cooling calculations. Other potential system improvements can then be discussed – e.g. filtering, offline or online cooling, etc. Contact us for further guidance and information.

## **Parker's quality and performance guarantee assures you of maximum system performance and reliability.**

A continual desire for more cost efficient and environmentally friendly hydraulic systems requires continuous development. Areas where we are continuously seeking to improve performance include cooling capacity, noise level, pressure drop and fatigue.

Meticulous quality and performance tests are conducted in our laboratory. All tests and

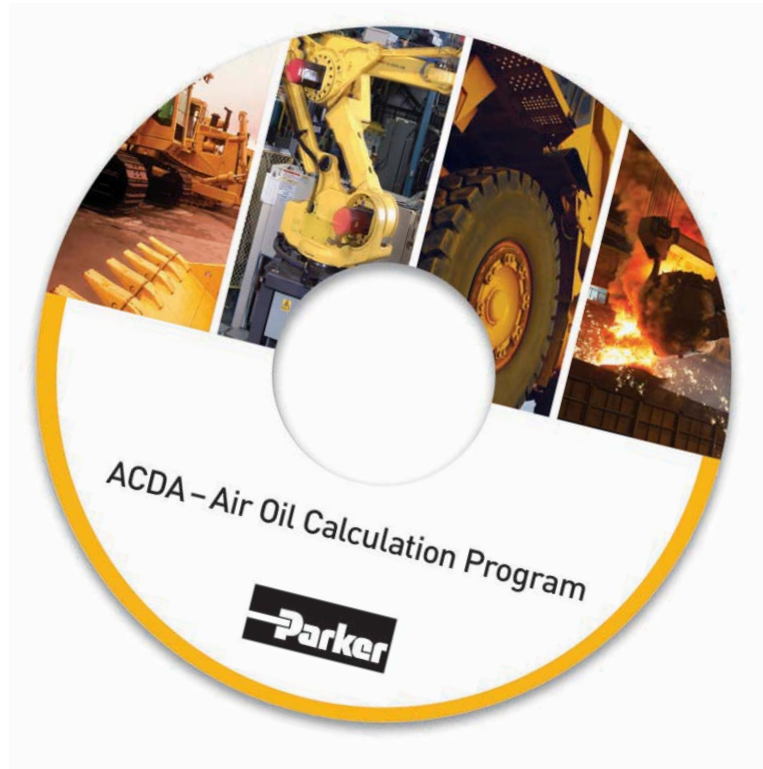

measurements take place in accordance with standardized methods – cooling capacity in accordance with EN1048, noise level ISO 3743, pressure drop EN 1048 and fatigue ISO 10771-1. For more information about our standardized tests, ask for "Parker's blue book – a manual for more reliable cooler purchasing."



# Calculate the cooling capacity requirement

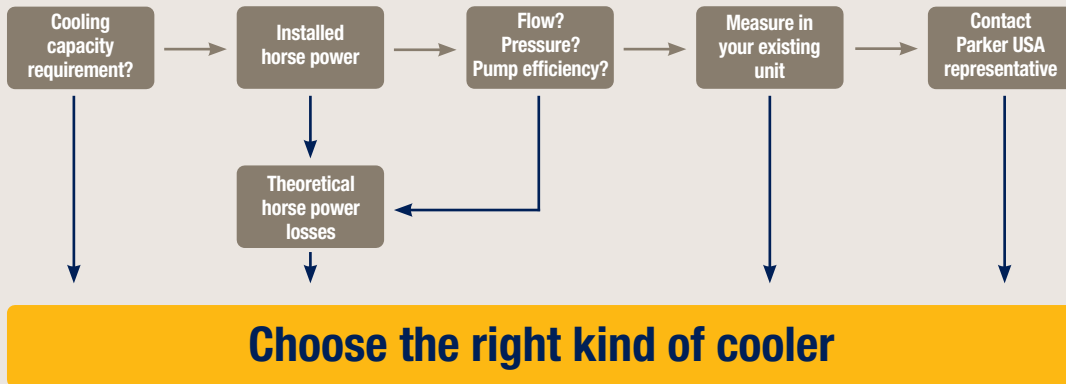

Enter your values ...

... get suggested solution





# ULAC with AC Motor

For industrial use – cooling capacity up to 400 HP



The ULAC oil cooler with AC motor is optimized for use in the industrial sector. Together with a wide range of accessories, the ULAC cooler is suitable for installation in most applications and environments.

- **Optimized design with right choice of materials and components ensures a reliable and long lasting cooler with low service and maintenance costs.**
- **Compact design resulting in lighter weight unit yet with higher cooling capacity and lower pressure drop.**
- **Easy to maintain and easy to retrofit into many applications.**
- **Quiet fan design due to optimization of material and blade design.**
- **AC motor – NEMA three phase motors are standard. Wide range of operating voltages and frequencies available.**
- **Cooler core with low pressure drop and high cooling capacity.**

# ULAC Cooling Performance

The cooling capacity curves are based on an ETD (Entering Temperature Difference) of 1 °F. For example, oil temperature of 140 °F and air temperature of 70 °F yields a temperature difference of 70 °F. Multiply the number from the cooling graphs corresponding to the specific flow rate by the ETD for the particular application to get the total heat duty.

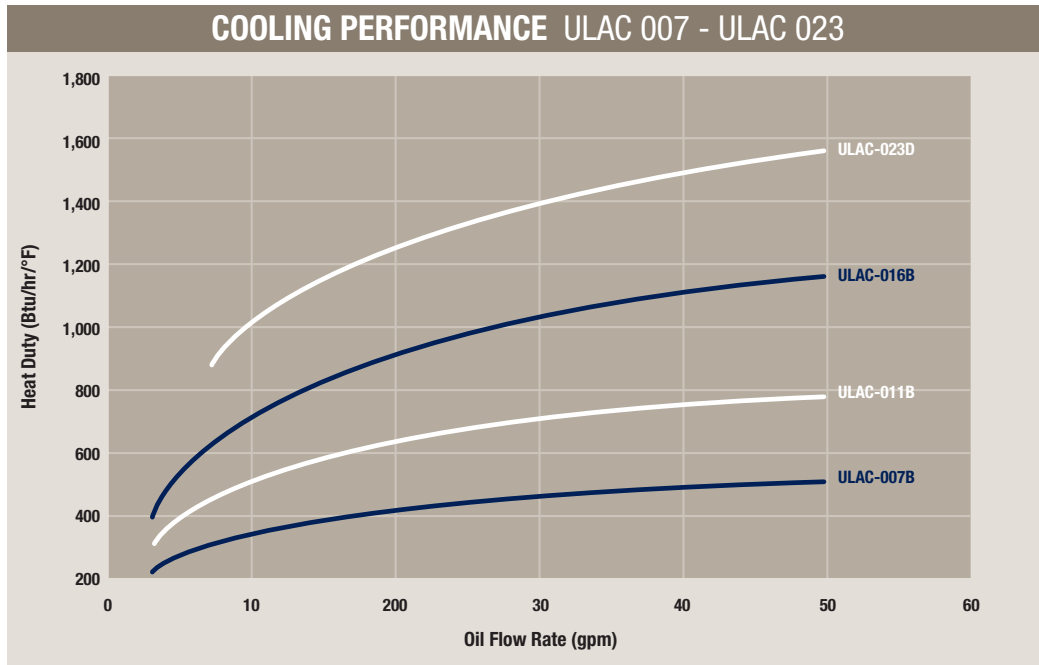

Cooling capacity tolerance ± 10%.

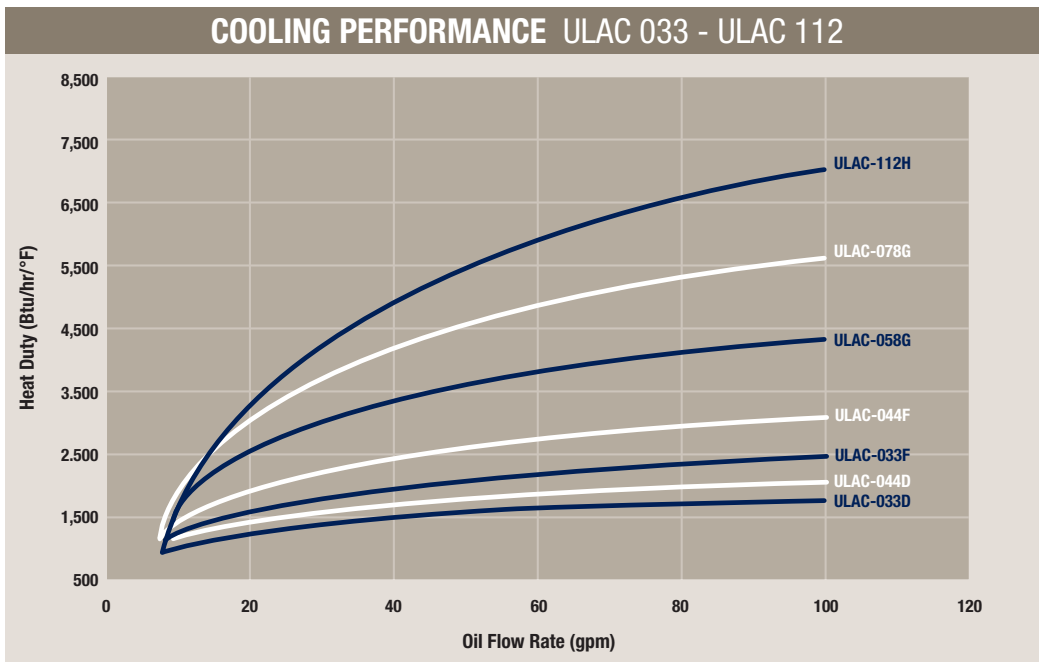

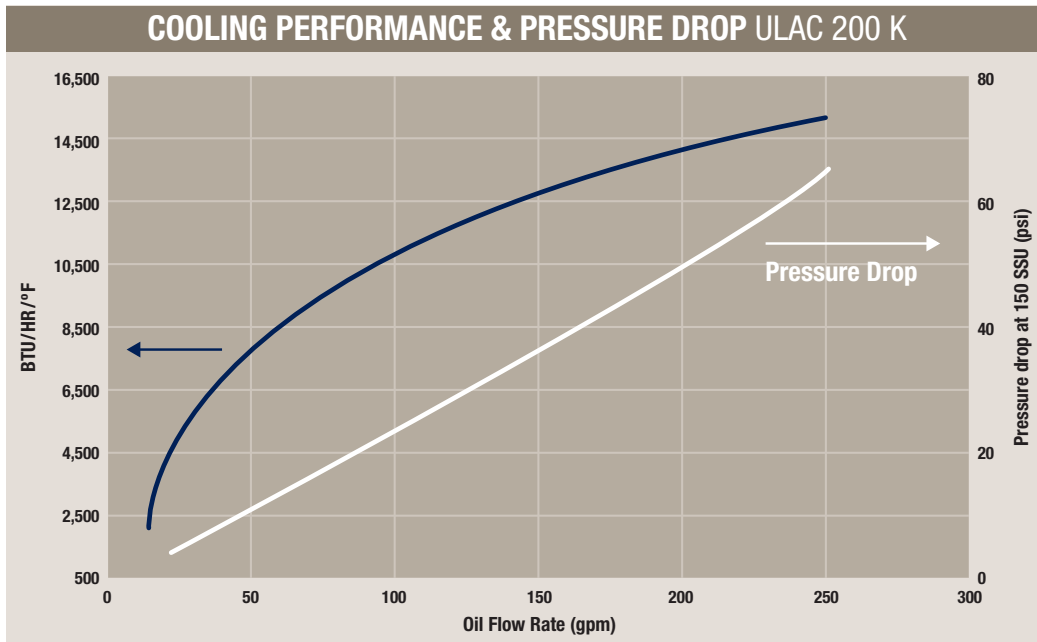

Cooling capacity tolerance  $\pm 10\%$ .

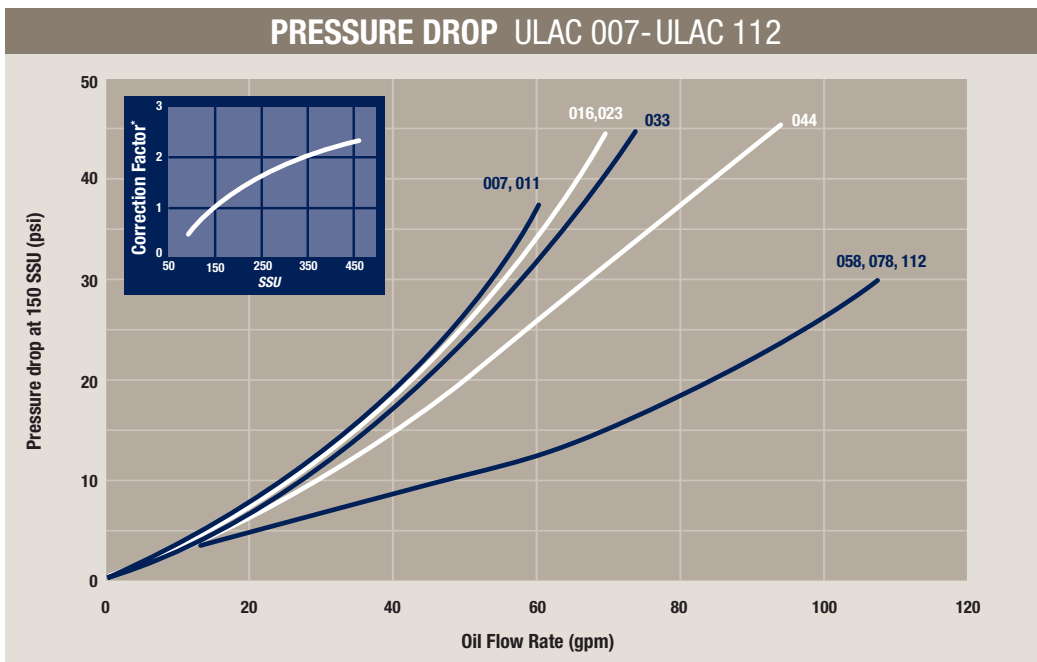

\* Pressure Drop Correction Factor for other viscosities.

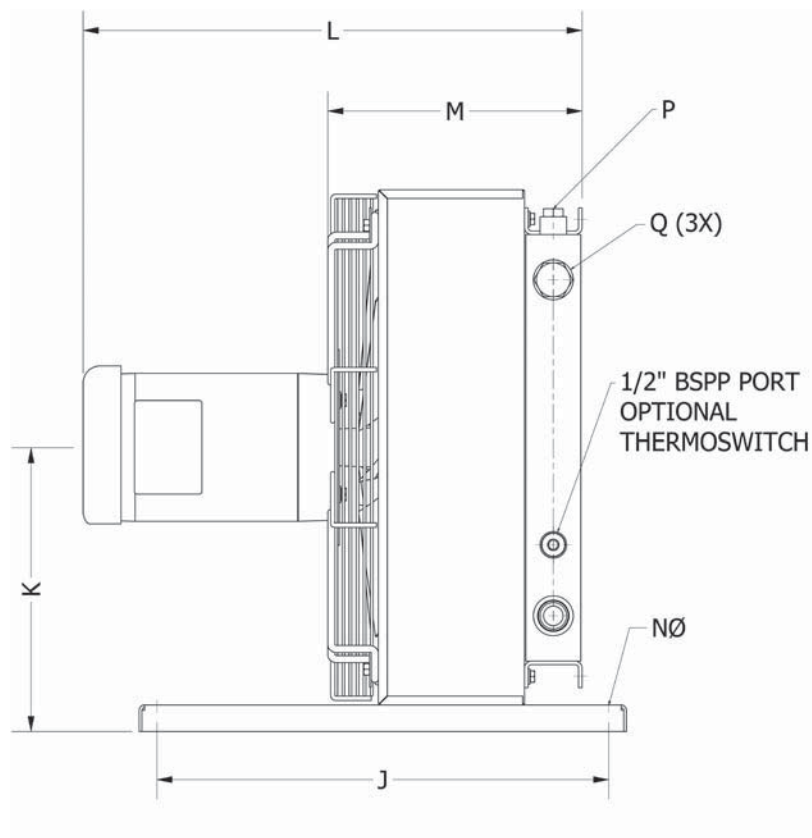

TYPE	Acoustic Pressure Level <i>L<sub>pA</sub> dB(A) 3 Ft. *</i>	No. Of Poles/ Capacity <i>HP</i>	Weight <i>Lbs. (Approx.)</i>	P <i>SAE O-Ring</i>	Q <i>SAE O-Ring Boss</i>
ULAC 007B	69	4/0.5	33	1/2" (#8)	1" (#16)
ULAC 011B	71	4/0.5	44	1/2" (#8)	1" (#16)
ULAC 016B	74	4/0.5	53	1/2" (#8)	1" (#16)
ULAC 023D	81	4/1	79	1/2" (#8)	1" (#16)
ULAC 033D	82	4/1	115	1/2" (#8)	1 1/4" (#20)
ULAC 033F	86	4/3	170	1/2" (#8)	1 1/4" (#20)
ULAC 044D	83	4/1	143	1/2" (#8)	1 1/4" (#20)
ULAC 044F	87	4/3	197	1/2" (#8)	1 1/4" (#20)
ULAC 058G	90	4/5	264	3/4" (#12)	1 1/2" (#24)
ULAC 078G	92	4/5	434	3/4" (#12)	1 1/2" (#24)
ULAC 112H	96	4/7.5	542	3/4" (#12)	1 1/2" (#24)
ULAC 200K	93	6/15	1,030	NA	CODE 61 SAE 2" FLANGE

\*Noise level tolerance  $\pm 3$  dB(A).



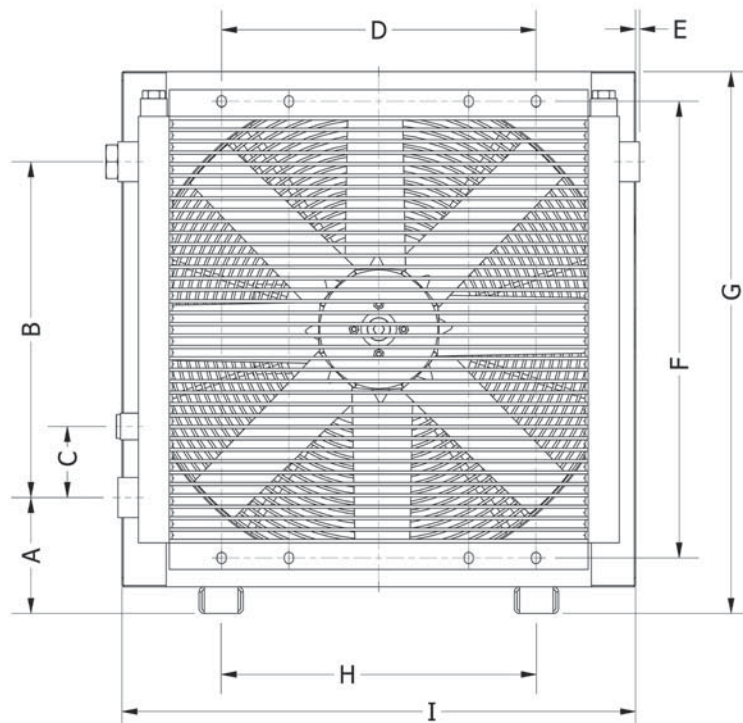

TYPE	A	B	C	D	E	F	G	H	I	J	K	L	M	Nø
ULAC 007B	5.2	6.3	3.2	8.0	0.24	11.7	15.6	8.0	14.4	20.1	8.4	19.8	8.8	0.35
ULAC 011B	5.4	9.0	3.2	8.0	0.12	14.3	18.5	8.0	17.3	20.1	9.8	20.8	9.8	0.35
ULAC 016B	5.2	11.7	3.2	8.0	0.28	17.0	20.7	8.0	19.5	20.1	10.9	21.6	10.7	0.35
ULAC 023D	5.2	14.9	3.2	14.0	0.20	20.2	24.0	14.0	22.8	20.1	12.6	22.2	11.3	0.35
ULAC 033D	5.2	19.1	3.2	14.0	NA	24.5	28.4	14.0	27.2	20.1	14.8	23.1	12.5	0.35
ULAC 033F	5.2	19.1	3.2	14.0	NA	24.5	28.4	14.0	27.2	24.0	14.8	25.6	12.5	0.55
ULAC 044D	4.6	26.1	3.2	14.0	NA	31.5	34.1	14.0	27.2	20.1	17.6	24.1	13.3	0.35
ULAC 044F	4.6	26.1	3.2	14.0	NA	31.5	34.1	14.0	27.2	24.0	18.3	26.6	13.5	0.55
ULAC 058G	5.2	26.1	3.2	20.0	NA	31.5	35.4	20.0	34.2	24.0	18.3	29.9	15.2	0.55
ULAC 078G	5.2	32.3	3.9	26.8	NA	38.9	41.4	20.4	40.2	35.4	21.1	30.9	16.2	0.55
ULAC 112H	5.1	38.8	3.9	31.1	0.14	45.4	47.8	23.6	46.7	35.4	24.4	31.9	17.2	0.55
ULAC 200K	7.2	50.9	5.0	49.6	1.2	61.0	64.2	55.9	59.4	35.4	32.7	41.5	18.7	0.71

All dimensions listed above are in inches.

## Order Key for ULAC Oil Coolers

All positions must be filled in when ordering.

EXAMPLE:					
ULAC	-	007B	- M	- 100	- SA
Series		Model	Motor Type	Thermoswitch	Core Bypass
1		2	3	4	5
<b>1. OIL COOLER SERIES WITH AC MOTOR; ULAC</b>					
<b>2. COOLER SIZE/MODEL</b>					
007B, 011B, 016B, 023D, 033F, 033D, 044F, 044D, 058G, 078G, 112H and 200K.					
<b>3. MOTOR TYPE</b>					
No motor					= W
Three-phase 190/380V 50 Hz, 208-230/460V 60 Hz					= M*
Three-phase 208-230/460V 60 Hz					= N
Three-phase 230/460V 60 Hz					= P
Three-phase 575V 60 Hz					= Q
Single-phase 115/230V 60 Hz					= R
Single-phase 230 V 60 Hz					= S
Explosion proof, Division 1, Class 1 Group D, Class II Group F & G, T3C					= X
Not listed, consult Accumulator and Cooler Division					= Z
*The M-motor is our standard motor sizes 1 HP and lower. The performance at 50 HZ will be reduced by approximately 10%					
<b>4. THERMOSWITCH</b>					
No thermoswitch					= 000
100 °F					= 100
120 °F					= 120
140 °F					= 140
160 °F					= 160
175 °F					= 175
195 °F					= 195
Not listed, consult Accumulator and Cooler Division					= ZZZ
<b>5. CORE BYPASS*</b>					
No Bypass					= SW
20 psi External Hose Bypass (standard option)					= SA
65 psi External Hose Bypass (standard option)					= SB
30 psi External Tube Bypass					= SG
75 psi External Tube Bypass					= SH
120 psi External Tube Bypass					= SJ
120 °F External Thermo-Bypass					= SM
140 °F External Thermo-Bypass					= SN
160 °F External Thermo-Bypass					= SP
195 °F External Thermo-Bypass					= SQ
Full Flow External Bypass					= SF
*The standard cores are single pass. Two pass cores and other options available upon request, please consult Accumulator and Cooler Division.					

## Technical Specifications

<b>FLUID COMBINATIONS</b>	
Mineral oil	
Oil/water emulsion	
Water glycol	
Phosphate ester	
<b>MATERIAL</b>	
Cooler core	Aluminum
Fan blades/hub	Glass fiber reinforced polypropylene/Aluminum
Fan housing	Steel
Fan guard	Steel
Other parts	Steel
Surface treatment	Electrostatically powder-coated
<b>COOLER CORE</b>	
Maximum static working pressure	300 psi
Dynamic working pressure	200 psi*
Heat transfer tolerance	± 6 %
Maximum oil inlet temperature	250 °F
*Tested in accordance with ISO/DIS 10771-1	
<b>COOLING CAPACITY CURVES</b>	
Cooling capacity curves are based on testing in accordance with EN1048 with ISO VG 46.	
<b>CONTACT PARKER FOR ADVICE ON</b>	
Oil temperatures > 250 °F	
Oil viscosity > 100 cSt / 500 SSU	
Aggressive environments	
Environments with heavy airborne particulates	
High-altitude locations	



The information in this brochure is subject to change without prior notice.

# ULOC Cooling System

For industrial use – cooling capacity up to 60 HP



The ULOC cooling system with three-phase AC motor is optimized for use in the industrial sector. The system is supplied ready for installation. An integrated circulation pump makes it possible to cool and treat the oil in a separate circuit – offline cooling. Together with a wide range of accessories, the ULOC cooling system is suitable for installation in most applications and environments.

- **Optimized design with right choice of materials and components ensures a reliable and long lasting cooler with low service and maintenance costs.**

- **Integrated circulation pump produces an even flow with low pressure pulsations.**
- **Easy to maintain and easy to retrofit in many applications.**
- **Compact design and low weight.**
- **Quiet fan and fan motor.**
- **Cooler core with low pressure drop and high cooling capacity.**

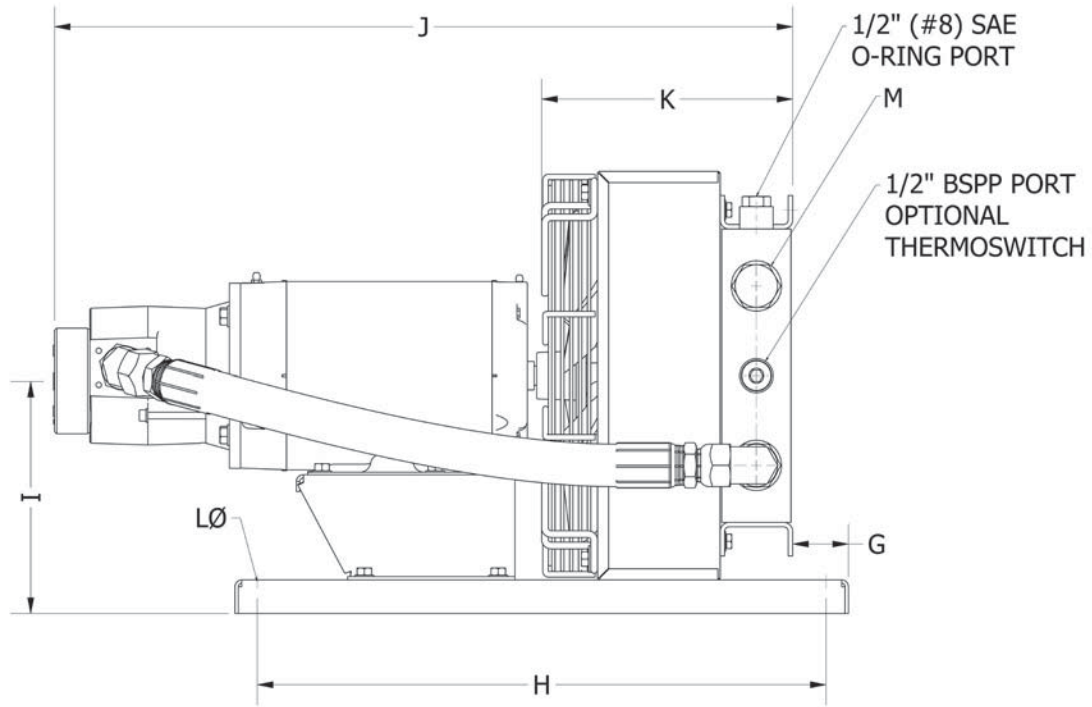

TYPE	Nom. Oil Flow Rate (gpm)	Cooling Capacity at 50 °F ETD (Btu/hr)	Cooling Capacity Btu/hr °F	Acoustic Pressure Level LpA dB(A) 3 Ft.*	Motor Capacity / No. Of Poles HP	Motor
ULOC 007D - A	6.3	15,500	310	71	1/4	1-4-143TC
ULOC 007D - B	12.7	19,000	380	71	1/4	1-4-143TC
ULOC 007E - C	19.0	21,000	420	72	2/4	2-4-145TC
ULOC 007E - D	25.4	22,500	450	72	2/4	2-4-145TC
ULOC 011D - A	6.3	24,000	480	74	1/4	1-4-143TC
ULOC 011D - B	12.7	28,500	570	74	1/4	1-4-143TC
ULOC 011E - C	19.0	32,000	640	74	2/4	2-4-145TC
ULOC 011E - D	25.4	34,500	690	74	2/4	2-4-145TC
ULOC 016E - A	6.3	33,500	670	78	2/4	2-4-145TC
ULOC 016E - B	12.7	41,000	820	78	2/4	2-4-145TC
ULOC 016E - C	19.0	47,000	940	78	2/4	2-4-145TC
ULOC 016E - D	25.4	50,000	1,000	78	2/4	2-4-145TC
ULOC 023F - B	12.7	60,000	1,200	82	3/4	3-4-182TC
ULOC 023F - C	19.0	65,000	1,300	82	3/4	3-4-182TC
ULOC 023F - D	25.4	70,000	1,400	82	3/4	3-4-182TC
ULOC 033G - C	19.0	80,000	1,600	87	5/4	5-4-182TC
ULOC 033G - D	25.4	90,000	1,800	87	5/4	5-4-184TC
ULOC 044G - C	19.0	95,000	1,900	88	5/4	5-4-182TC
ULOC 044G - D	25.4	105,000	2,100	88	5/4	5-4-182TC

Electric motors specified are calculated for max. Working pressure 90 psi at 125 cSt and 50 Hz, 60 psi at 125 cSt and 60 Hz. If you require higher pressure, please contact us for a choice of motors with a higher output.

\* Noise level tolerance ± 3 dB(A).



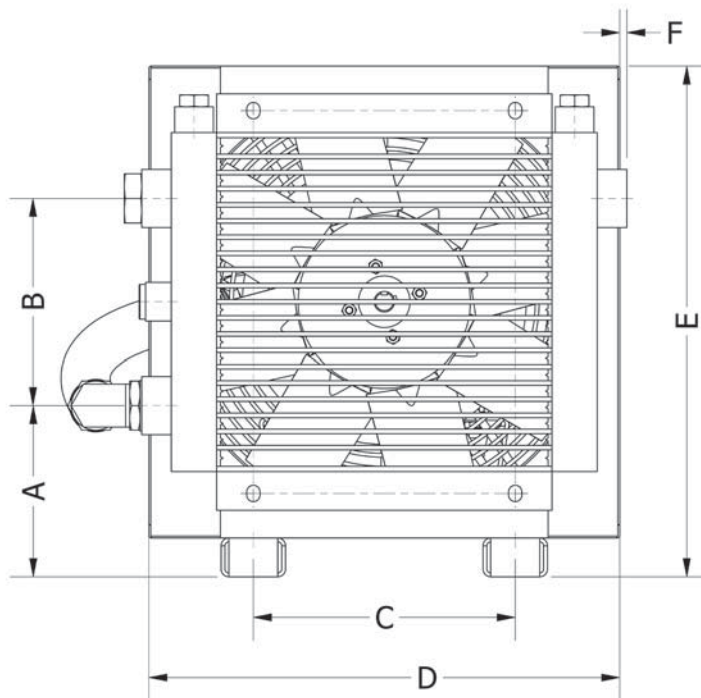

TYPE	A	B	C	D	E	F	G	H	I	J	K	L $\phi$	M SAE O-Ring Boss*
ULOC 007D - A	5.2	6.3	8.0	14.4	15.6	0.2	2.0	20.1	8.5	26.1	8.9	0.35	1" (#16)
ULOC 007D - B	5.2	6.3	8.0	14.4	15.6	0.2	2.0	20.1	8.5	26.6	8.9	0.35	1" (#16)
ULOC 007E - C	5.2	6.3	8.0	14.4	15.6	0.2	2.0	20.1	8.5	27.1	8.9	0.35	1" (#16)
ULOC 007E - D	5.2	6.3	8.0	14.4	15.6	0.2	2.0	20.1	8.5	27.6	8.9	0.35	1" (#16)
ULOC 011D - A	5.3	9.0	8.0	17.3	18.5	0.1	2.0	20.1	9.9	27.0	9.9	0.35	1" (#16)
ULOC 011D - B	5.3	9.0	8.0	17.3	18.5	0.1	2.0	20.1	9.6	27.4	9.8	0.35	1" (#16)
ULOC 011E - C	5.4	9.0	8.0	17.3	18.5	0.1	2.0	20.1	9.9	28.0	9.8	0.35	1" (#16)
ULOC 011E - D	5.4	9.0	8.0	17.3	18.5	0.1	2.0	20.1	9.6	28.5	9.8	0.35	1" (#16)
ULOC 016E - A	5.1	11.7	8.0	19.5	20.7	0.3	2.0	20.1	11.0	27.7	10.7	0.35	1" (#16)
ULOC 016E - B	5.1	11.7	8.0	19.5	20.7	0.3	2.0	20.1	11.0	28.2	10.7	0.35	1" (#16)
ULOC 016E - C	5.1	11.7	8.0	19.5	20.7	0.3	2.0	20.1	11.0	28.8	10.7	0.35	1" (#16)
ULOC 016E - D	5.1	11.7	8.0	19.5	20.7	0.3	2.0	20.1	10.7	29.3	10.7	0.35	1" (#16)
ULOC 023F - B	5.2	14.9	14.0	22.8	24.0	0.2	2.0	24.0	12.4	30.7	11.3	0.55	1" (#16)
ULOC 023F - C	5.1	14.9	14.0	22.8	24.0	0.2	2.0	24.0	12.4	31.2	11.3	0.55	1" (#16)
ULOC 023F - D	5.1	14.9	14.0	22.8	24.0	0.2	2.0	24.0	12.4	31.7	11.3	0.55	1" (#16)
ULOC 033G - C	5.2	19.1	14.0	27.2	28.4	-	2.4	24.0	14.6	32.7	12.5	0.55	1¼" (#20)
ULOC 033G - D	5.2	19.1	14.0	27.2	28.4	-	2.4	24.0	14.9	33.2	12.5	0.55	1¼" (#20)
ULOC 044G - C	4.5	26.1	14.0	27.2	34.1	-	2.0	24.0	17.4	33.6	13.5	0.55	1¼" (#20)
ULOC 044G - D	4.5	26.1	14.0	27.2	34.1	-	2.0	24.0	17.4	33.9	13.5	0.55	1¼" (#20)

\* Port on the inlet side of the pump is 1½" (#24) SAE O-ring Boss for all models.  
All dimensions listed above are in inches.

## Order Key for ULOC Cooling Systems

All positions must be filled in when ordering.

EXAMPLE:					
ULOC	-	007D	- M	- A	- SA
Series		Model	Motor Type	Pump Flow Rate	Core Bypass
1		2	3	4	5
<b>1. OIL COOLER SERIES OFFLINE, WITH PUMP; ULOC</b>					
<b>2. COOLER SIZE/MODEL</b>					
007D, 007E, 011D, 011E, 016E, 023F, 033G, 044G					
<b>3. MOTOR TYPE</b>					
No motor					= W
Three phase, 190/380V 50 Hz, 208-230/460V 60Hz					= M
Three phase, 575V 60Hz					= Q
Not listed, consult Accumulator and Cooler Division					= Z
<i>Performance at 50 Hz will be reduced by approximately 10%</i>					
<b>4. PUMP FLOW RATE (GPM)</b>					
6					= A
12					= B
19					= C
25					= D
<b>5. CORE BYPASS*</b>					
No Bypass					= SW
20 psi External Hose Bypass (standard option)					= SA
65 psi External Hose Bypass (standard option)					= SB
30 psi External Tube Bypass					= SG
75 psi External Tube Bypass					= SH
120 psi External Tube Bypass					= SJ
120 °F External Thermo-Bypass					= SM
140 °F External Thermo-Bypass					= SN
160 °F External Thermo-Bypass					= SP
195 °F External Thermo-Bypass					= SQ
<i>*The standard cores are single pass. Two pass cores and other options available upon request, please consult Accumulator and Cooler Division.</i>					

## Technical Specifications

<b>COOLER CORE</b>	
Maximum static working pressure	300 psi
Dynamic working pressure	200 psi*
Heat transfer tolerance	± 6 %
Maximum oil inlet temperature	250 °F
<i>* Tested in accordance with ISO/DIS 10771-1</i>	
<ul style="list-style-type: none"> <li>ULOC is designed primarily for synthetic oils, vegetable oils and mineral oil type HL/HLP in accordance with DIN 51524. Maximum oil temperature 210 °F.</li> <li>Maximum negative pressure in the inlet line is 6 psi with an oil-filled pump. Maximum pressure on the pump's suction side is 8 psi.</li> <li>Maximum working pressure for the pump is 150 psi.</li> </ul>	
Heat transfer tolerance	± 6 %
<b>MATERIAL</b>	
Cooler core	Aluminum
Fan blades/hub	Glass fiber reinforced polypropylene/ Aluminum
Fan housing	Steel
Fan guard	Steel
Pump housing	Aluminum
Other parts	Steel
Surface treatment	Electrostatically powder-coated
<b>CONTACT PARKER FOR ADVICE ON</b>	
Oil temperatures > 250 °F	
Oil viscosity > 100 cSt / 500 SSU	
Aggressive environments	
Environments with heavy airborne particulates	
High-altitude locations	

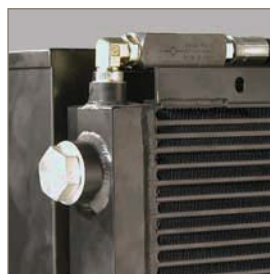

Bypass Valve



Stone Guard

The information in this brochure is subject to change without prior notice.

# ULDC With DC Motor

For mobile use – cooling capacity up to 40 HP



The ULDC oil cooler with 12 or 24V DC motor is optimized for use in the mobile industry. Together with a wide range of accessories, the ULDC cooler is suitable for installation in most applications and environments.

- **Optimized design with right choice of materials and components ensures a reliable and long lasting cooler with low service and maintenance costs.**
- **Compact design resulting in lighter weight unit yet with higher cooling capacity and lower pressure drop.**
- **Easy to maintain and easy to retrofit into many applications.**
- **DC motor 12V/24V.**
- **Quiet fan and fan motor.**

# ULDC Cooling Performance

The cooling capacity curves are based on an ETD (Entering Temperature Difference) of 1 °F. For example, oil temperature of 140 °F and air temperature of 70 °F yields a temperature difference of 70 °F. Multiply the number from the cooling graphs corresponding to the specific flow rate by the ETD for the particular application to get the total heat duty.

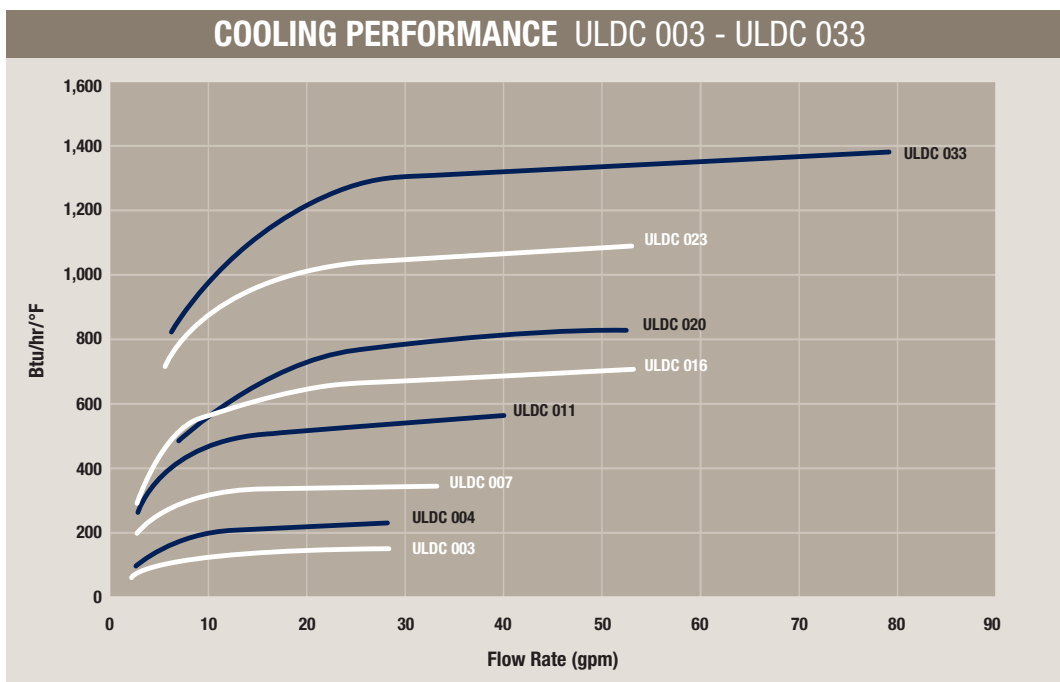

Cooling capacity tolerance ± 10%.

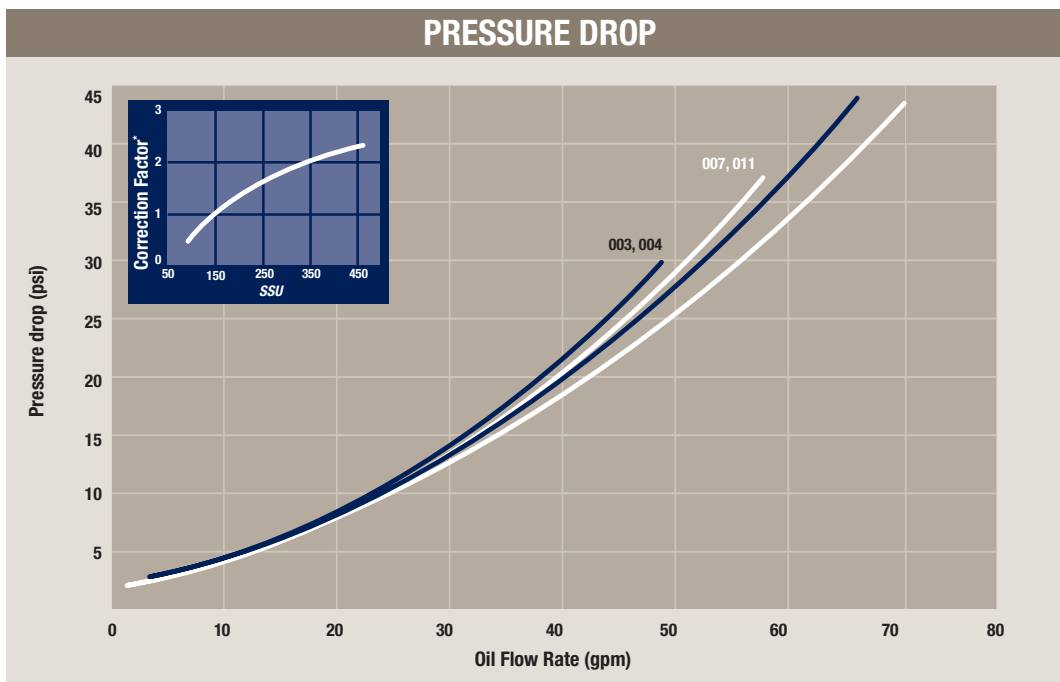

\* Pressure Drop Correction Factor for other viscosities.



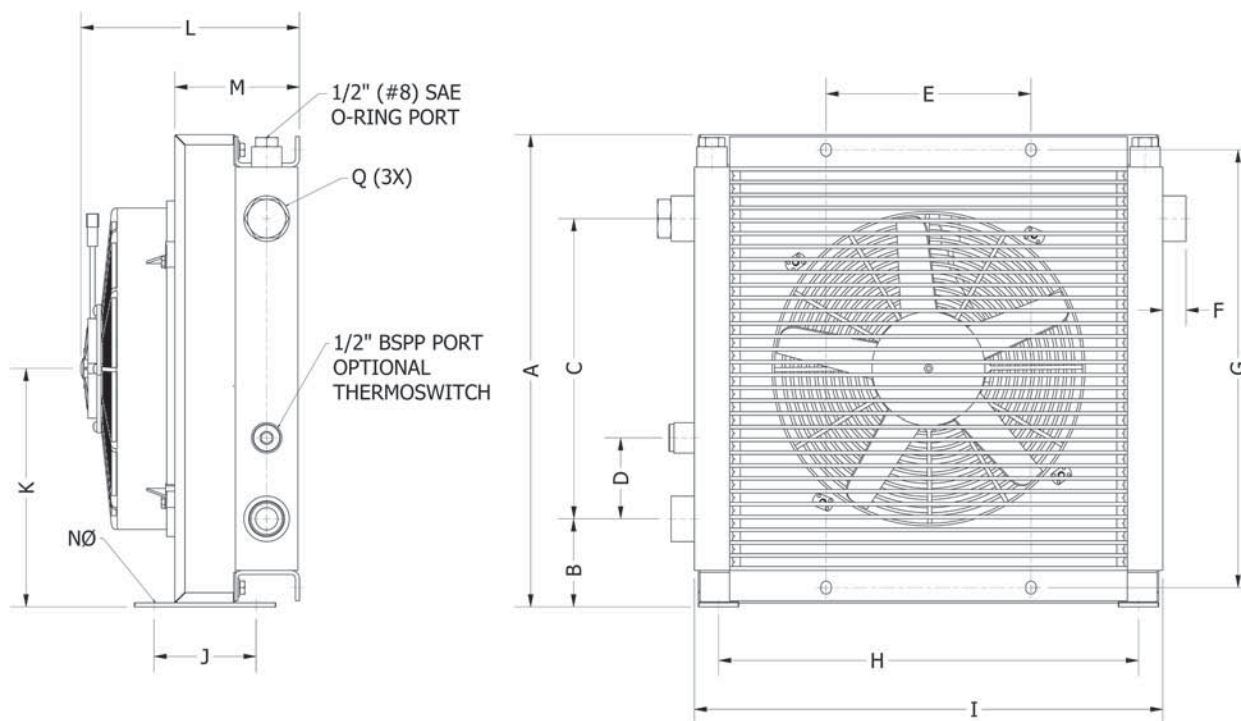

TYPE	Weight lbs (Approx.)	Acoustic Pressure LpA dB(A) 3 Ft.*	Max. Current (Amps.)**		Q SAE O-Ring Boss
			12 Volts	24 Volts	
ULDC 003	11	68	9	3	1" (#16)
ULDC 004	13	63	7	4	1" (#16)
ULDC 007	20	71	13	6	1" (#16)
ULDC 011	26	75	20	12	1" (#16)
ULDC 016	33	75	20	12	1" (#16)
ULDC 020	40	82	20	10	1" (#16)
ULDC 023	55	75	20	12	1" (#16)
ULDC 033	66	75	20	12	1¼" (#20)

\* Noise level tolerance ± 3 dB(A).

\*\* ULDC-023 & ULDC-033 Cooler assemblies come with two fans each. The indicated max. current is for one fan only.

TYPE	A	B	C	D	E	F	G	H	I	J	K	L	M	NØ dia./oblong
ULDC 003	8.9	2.5	3.5	-	5.2	0.9	7.8	5.3	9.6	5.8	4.6	5.9	4.1	0.35 x 0.55
ULDC 004	10.0	3.5	3.5	-	6.0	0.9	9.0	5.3	10.5	5.8	5.2	6.0	4.3	0.35 x 0.55
ULDC 007	13.3	3.7	6.3	3.2	8.0	0.9	11.7	8.0	13.0	10.5	6.8	6.8	4.3	0.35
ULDC 011	15.6	3.4	9.0	3.2	8.0	0.9	14.3	14.2	15.7	4.0	7.9	8.5	4.9	0.35 x 1.1
ULDC 016	18.3	3.4	11.7	3.2	8.0	0.9	17.0	16.4	18.3	4.0	9.3	8.3	4.8	0.35 x 1.1
ULDC 020	20.1	3.0	13.8	2.8	8.0	0.9	18.7	18.5	20.1	4.0	10.1	8.3	4.9	0.35 x 0.55
ULDC 023	25.0	5.4	14.9	3.2	14.0	-	20.2	-	24.2	11.4	7.9/18.0	8.6	4.9	0.51
ULDC 033	26.7	3.4	19.1	3.2	14.0	1.0	24.5	-	25.0	11.4	7.9/18.0	10.1	6.5	0.51

All dimensions listed above are in inches.

## Order Key for ULDC Oil Coolers

All positions must be filled in when ordering.

EXAMPLE:					
ULDC	-	007	- A	- 000	- SA
Series		Model	Motor Type	Thermoswitch	Core Bypass
1		2	3	4	5
<b>1. OIL COOLER SERIES WITH DC MOTOR; ULDC</b>					
<b>2. COOLER SIZE/MODEL</b>					
003, 004, 007, 011, 016, 020, 023, 033					
<b>3. MOTOR VOLTAGE</b>					
12 V					= A
24 V					= B
<b>4. THERMOSWITCH</b>					
No thermoswitch					= 000
100 °F					= 100
120 °F					= 120
140 °F					= 140
160 °F					= 160
175 °F					= 175
195 °F					= 195
Not listed, consult Accumulator and Cooler Division					= ZZZ
<b>5. CORE BYPASS*</b>					
No Bypass					= SW
20 psi External Hose Bypass (standard option)					= SA
65 psi External Hose Bypass (standard option)					= SB
30 psi External Tube Bypass					= SG
75 psi External Tube Bypass					= SH
120 psi External Tube Bypass					= SJ
120 °F External Thermo-Bypass					= SM
140 °F External Thermo-Bypass					= SN
160 °F External Thermo-Bypass					= SP
195 °F External Thermo-Bypass					= SQ
Full Flow External Bypass					= SF
* The standard cores are single pass. Two pass cores and other options available upon request, please consult Accumulator and Cooler Division.					

## Technical Specifications

<b>FLUID COMBINATIONS</b>	
Mineral oil	
Oil/water emulsion	
Water glycol	
Phosphate ester	
<b>MATERIAL</b>	
Cooler core	Aluminum
Fan blades/guard	Glass fiber reinforced polypropylene
Fan housing	Steel
Other parts	Steel
Surface treatment	Electrostatically powder-coated
<b>COOLER CORE</b>	
Maximum static working pressure	300 psi
Dynamic working pressure	200 psi*
Heat transfer tolerance	± 6 %
Maximum oil inlet temperature	250 °F
* Tested in accordance with ISO/DIS 10771-1	
<b>COOLING CAPACITY CURVES</b>	
The cooling capacity curves in this catalogue are created using oil type ISO VG 46 at 250 °F.	
<b>CONTACT PARKER FOR ADVICE ON</b>	
Oil temperatures > 250 °F	
Oil viscosity > 100 cSt / 500 SSU	
Aggressive environments	
Environments with heavy airborne particulates	
High-altitude locations	



The information in this brochure is subject to change without prior notice.

# ULHC With Hydraulic Motor

For mobile and industrial use – maximum cooling capacity 215 HP



The ULHC oil cooler with hydraulic motor is optimized for use in the mobile and industrial sector. Together with a wide range of accessories, the ULHC cooler is suitable for installation in most applications and environments.

- **Optimized design with right choice of materials and components ensures a reliable and long lasting cooler with low service and maintenance costs.**
- **Compact design resulting in lighter weight unit yet with higher cooling capacity and lower pressure drop.**
- **Easy to maintain and easy to retrofit into many applications.**
- **Hydraulic motor with displacement from 8.4 cc/rev to 25.2 cc/rev.**
- **Collar bearing for fan motor on larger models provides longer operating life.**
- **Quiet fan design due to optimization of material and blade design.**
- **Cooler core with low pressure drop and high cooling capacity.**

# ULHC Cooling Performance

The cooling capacity curves are based on an ETD (Entering Temperature Difference) of 1 °F. For example, oil temperature of 140 °F and air temperature of 70 °F yields a temperature difference of 70 °F. Multiply the number from the cooling graphs corresponding to the specific flow rate by the ETD for the particular application to get the total heat duty.

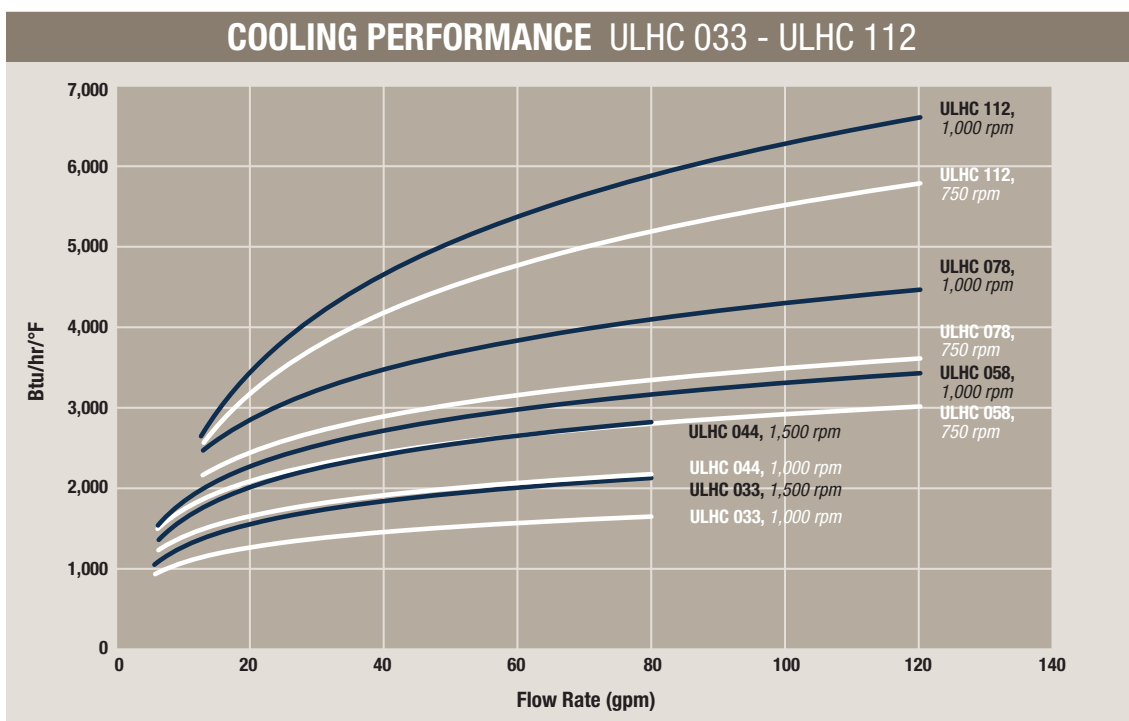
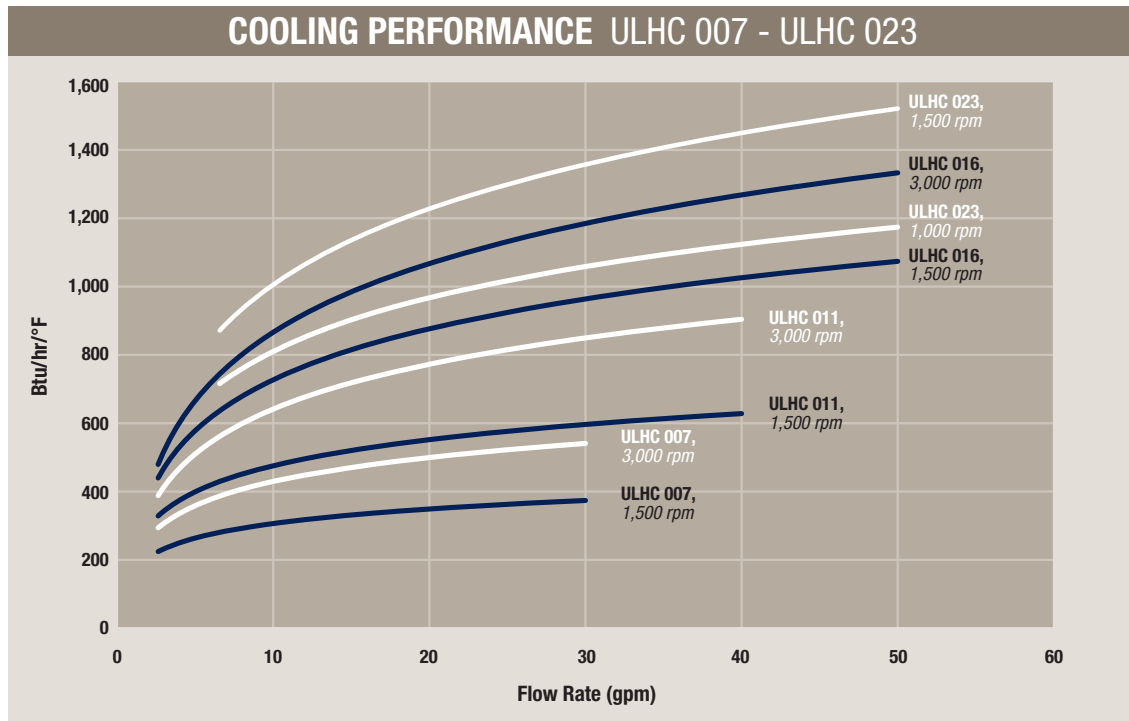

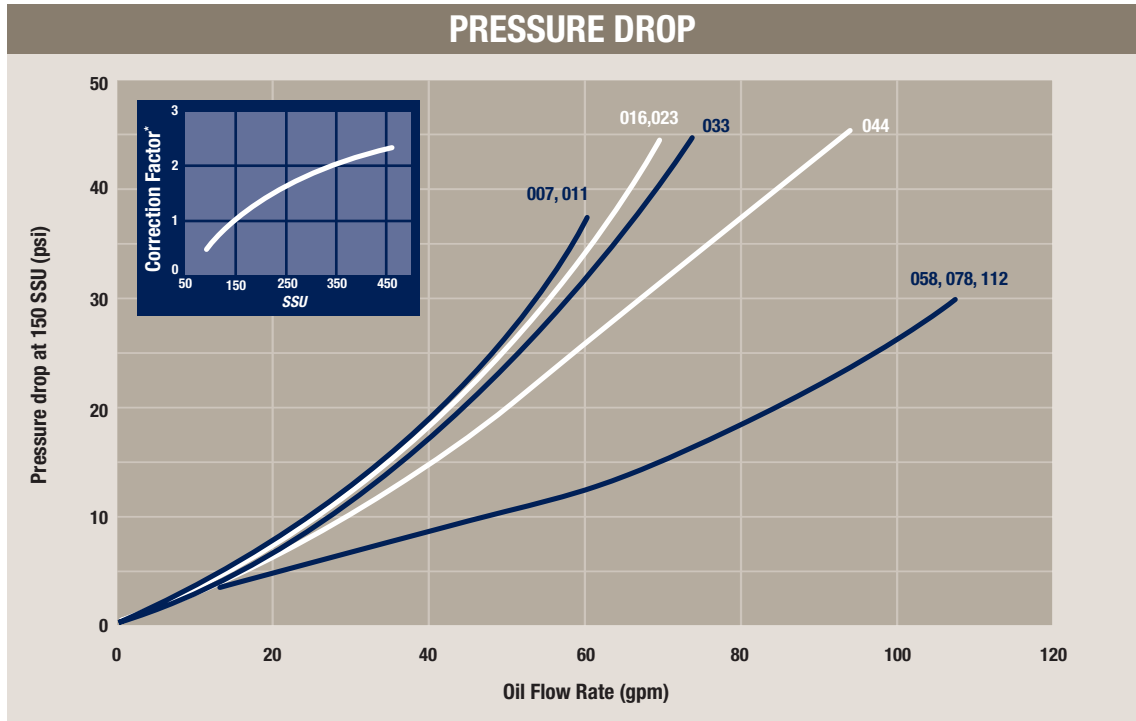

\* Pressure Drop Correction Factor for other viscosities.



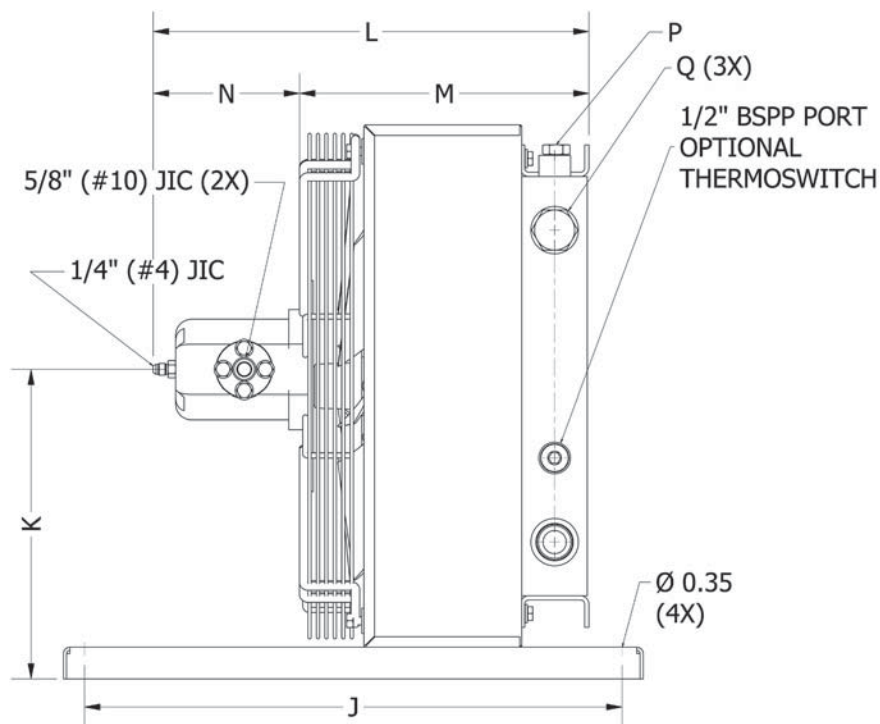

TYPE	Fan Speed <i>rpm</i>	Fan Power <i>HP</i>	Weight <i>lbs. (Approx.)</i>	Max Speed <i>rpm</i>	Acoustic Pressure Level <i>LpA dB(A) 3 Ft*</i>
ULHC 007	1,500	0.13	22	3,500	62
	3,000	0.87	22	3,500	79
ULHC 011	1,500	0.27	33	3,500	67
	3,000	2.01	33	3,500	82
ULHC 016	1,500	0.13	40	3,500	60
	3,000	0.47	40	3,500	70
ULHC 023	1,000	0.20	66	2,840	64
	1,500	0.67	66	2,840	76
ULHC 033	1,000	0.87	88	2,350	75
	1,500	2.68	88	2,350	85
ULHC 044	1,000	0.94	123	2,350	77
	1,500	2.68	123	2,350	86
ULHC 058	750	1.01	170	1,850	75
	1,000	2.41	170	1,850	83
ULHC 078	750	0.94	245	1,690	81
	1,000	2.15	245	1,690	88
ULHC 112	750	2.28	276	1,440	86
	1,000	5.36	276	1,440	92

\* Noise level tolerance  $\pm 3$  dB(A).

MOTOR	Displacement <i>cm<sup>3</sup>/r</i>	N <i>ULHC 007 - ULHC 023</i>	N <i>ULHC 033 - ULHC 112</i>	Max. Working Pressure <i>psi</i>
A	8.4	4.5	6.1	3,000
B	10.8	4.8	6.3	3,000
C	14.4	4.9	6.6	3,000
D	16.8	5.0	6.7	3,000
E	19.2	5.2	6.9	3,000
F	25.2	5.6	7.4	2,330

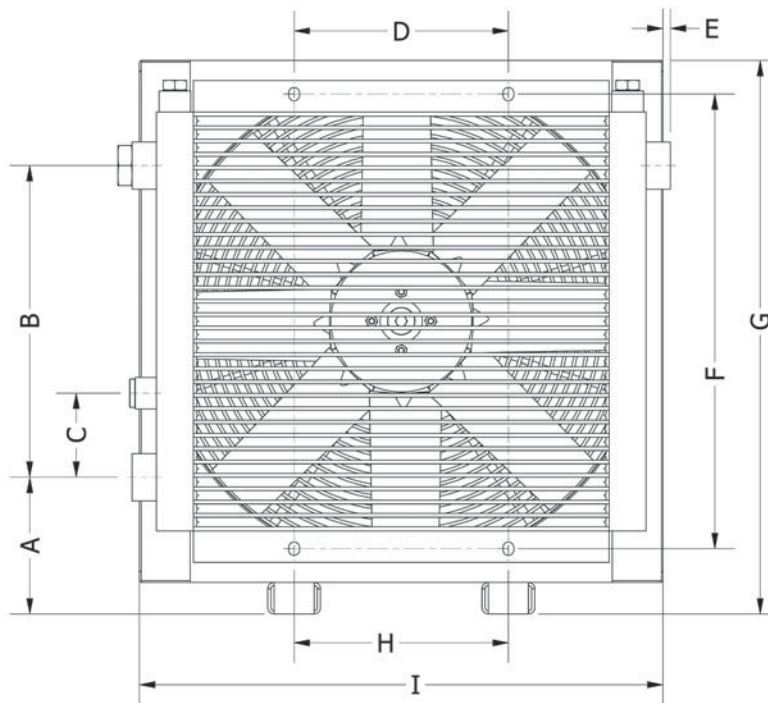

TYPE	A	B	C	D	E	F	G	H	I	J	K
ULHC 007	5.2	6.3	3.2	8.0	0.2	11.7	15.6	8.0	14.4	20.1	7.8
ULHC 011	5.4	9.0	3.2	8.0	0.1	14.3	18.5	8.0	17.3	20.1	9.2
ULHC 016	5.1	11.7	3.2	8.0	0.3	17.0	20.7	8.0	19.5	20.1	11.6
ULHC 023	5.2	14.9	3.2	14.0	0.2	20.2	24.0	14.0	22.8	20.1	12.0
ULHC 033	5.2	19.1	3.2	14.0	-	24.5	28.4	14.0	27.2	20.1	14.2
ULHC 044	4.6	26.1	3.2	14.0	-	31.5	34.1	14.0	27.2	20.1	17.0
ULHC 058	5.2	26.1	3.2	20.0	-	31.5	35.4	20.0	34.2	20.1	17.6
ULHC 078	5.2	32.3	3.9	26.8	-	38.9	41.4	20.4	40.2	24.0	20.7
ULHC 112	5.1	38.8	3.9	31.1	0.2	45.4	47.8	23.6	46.7	24.0	23.9

All dimensions listed above are in inches.

TYPE	L (Max)	M	P SAE O-ring	Q SAE O-ring Boss	Motor Selection
ULHC 007	14.4	8.9	½" (#8)	1" (#16)	A - F
ULHC 011	15.3	9.8	½" (#8)	1" (#16)	A - F
ULHC 016	16.3	10.8	½" (#8)	1" (#16)	A - F
ULHC 023	16.6	11.1	½" (#8)	1" (#16)	A - F
ULHC 033	19.7	12.5	½" (#8)	1¼" (#20)	A - F
ULHC 044	20.7	13.5	½" (#8)	1¼" (#20)	A - F
ULHC 058	22.4	15.3	¾" (#12)	1½" (#24)	A - F
ULHC 078	21.4	16.3	¾" (#12)	1½" (#24)	B - F
ULHC 112	24.4	17.2	¾" (#12)	1½" (#24)	D - F

## Order Key for ULHC Oil Coolers

All positions must be filled in when ordering.

<b>EXAMPLE:</b>								
<b>ULHC</b>	<b>-</b>	<b>007</b>	<b>-</b>	<b>A</b>	<b>-</b>	<b>120</b>	<b>-</b>	<b>SA</b>
<i>Series</i>		<i>Model</i>		<i>Hydraulic motor displacement</i>		<i>Thermoswitch</i>		<i>Core Bypass</i>
1		2		3		4		5
<b>1. OIL COOLER SERIES WITH HYDRAULIC MOTOR; ULHC</b>								
<b>2. COOLER SIZE/MODEL</b>								
007, 011, 016, 023, 033, 044, 058, 078 and 112.								
<b>3. HYDRAULIC MOTOR, DISPLACEMENT</b>								
No hydraulic motor = W								
Displacement 8.4 cm <sup>3</sup> /rev. = A								
Displacement 10.8 cm <sup>3</sup> /rev. = B								
Displacement 14.4 cm <sup>3</sup> /rev. = C								
Displacement 16.8 cm <sup>3</sup> /rev. = D								
Displacement 19.2 cm <sup>3</sup> /rev. = E								
Displacement 25.2 cm <sup>3</sup> /rev. = F								
Not listed, consult Accumulator and Cooler Division = Z								
<b>4. THERMO CONTACT</b>								
No thermoswitch = 000								
100 °F = 100								
120 °F = 120								
140 °F = 140								
160 °F = 160								
175 °F = 175								
195 °F = 195								
Not listed, consult Accumulator and Cooler Division = ZZZ								
<b>5. CORE BYPASS*</b>								
No Bypass = SW								
20 psi External Hose Bypass (standard option) = SA								
65 psi External Hose Bypass (standard option) = SB								
30 psi External Tube Bypass = SG								
75 psi External Tube Bypass = SH								
120 psi External Tube Bypass = SJ								
120 °F External Thermo-Bypass = SM								
140 °F External Thermo-Bypass = SN								
160 °F External Thermo-Bypass = SP								
195 °F External Thermo-Bypass = SQ								
Full Flow External Bypass = SF								
*The standard cores are single pass. Two pass cores and other options available upon request, please consult Accumulator and Cooler Division.								

## Technical Specifications

<b>FLUID COMBINATIONS</b>	
Mineral oil	
Oil/water emulsion	
Water glycol	
Phosphate ester	
<b>MATERIAL</b>	
Cooler core	Aluminum
Fan blades/Housing	Glass fiber reinforced polypropylene/Aluminum
Fan housing	Steel
Fan guard	Steel
Other parts	Steel
Surface treatment	Electrostatically powder-coated
<b>COOLER CORE</b>	
Maximum static operating pressure	300 psi
Dynamic operating pressure	200 psi*
Heat transfer tolerance	± 6 %
Maximum oil inlet temperature	250 °F
* Tested in accordance with ISO/DIS 10771-1	
<b>COOLING CAPACITY CURVES</b>	
The cooling capacity curves in this catalog are being created using oil type ISO VG 46 at 140 °F.	
<b>CONTACT PARKER FOR ADVICE ON</b>	
Oil temperatures > 250 °F	
Oil viscosity > 100 cSt / 500 SSU	
Aggressive environments	
Environments with heavy airborne particulates	
High-altitude locations	



The information in this brochure is subject to change without prior notice.

# OAW Water Oil Cooler

For mobile and industrial use



The OAW oil cooler is optimized for use in mobile and industrial sectors. Together with a wide range of accessories, the OAW cooler is suitable for installation in most applications and environments.

- **Optimized design and the right choice of materials and components ensure reliable and long-lasting cooling with low service and maintenance costs.**
- **Compact design for easy installation.**
- **Turbulent water flow prevents clogging and reduces maintenance.**
- **Low water consumption for economical operation.**
- **SAE O-ring connections for ease of assembly and leak-proof operation.**
- **Maximum material efficiency with no “Dead Zone.”**

# General

Our OAW coolers are designed for a maximum working pressure of 450 psi. The most standard application for the OAW cooler involves a cold water circuit and a hot oil circuit. Fluids are not limited to oil and water however; see the Fluid Compatibility section in the OAW product literature for more information. Inlets and outlets are clearly identified by the Accumulator and Cooler Division sticker affixed to the front of the unit. When in doubt, pour a liquid in one of the connections and note which connection it comes out of. This will be the inlet and outlet for one circuit (either oil or water). The other inlet should be located on the diagonal from the first inlet. Maximum cooling efficiency is achieved by cross flowing through the plates, the oil inlet and water inlet being located on a diagonal.

## OAW to the max.

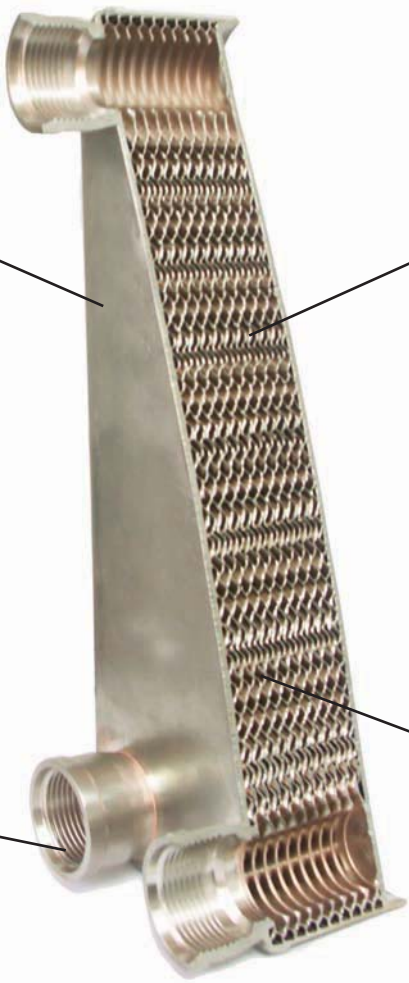

**Extremely Compact:**  
85-90% Reduction in volume and weight of a shell-and-tube heat exchanger of the same capacity.

**LOW WATER CONSUMPTION. ECONOMICAL OPERATION COMPACT.**

**Corrugated:**  
Plates made of 316 stainless steel brazed with pure copper.

**TURBULENT WATER FLOW PREVENTS CLOGGING AND REDUCES MAINTENANCE. SMALLER SIZE MAKES IT EASY TO INSTALL.**

**BROAD RANGE: SEVERAL MODELS IN-STOCK FOR IMMEDIATE DELIVERY.**

**SAE O-Ring Connections:**  
Good for ease of assembly and leak proof operation.

**Maximum Efficiency:**  
Maximum material efficiency. No "Dead Zone" because there is no need for gaskets. Up to 25% more capacity utilization.



### OAW 14 & OAW 34

MODEL	Cooling Capacity (*hp)	Connection	A (inches)	Weight (lbs.)	Volume (in <sup>3</sup> )
OAW 14-10-SG	2-7	5/8" SAE O-ring	1.4	1.4	15
OAW 34-20	6-33	1" SAE O-ring	2.3	9	74
OAW 34-40	20-69	1" SAE O-ring	4.1	15	149

\*Cooling capacity is calculated with the following conditions. For other flow conditions, type of fluids or temperatures, please see page 35 or consult Accumulator and Cooler Division. Oil type – ISO VG 32 – Oil/water flow ratio – 2:1 – Oil inlet temperature – 140°F – Water inlet temperature – 80°F

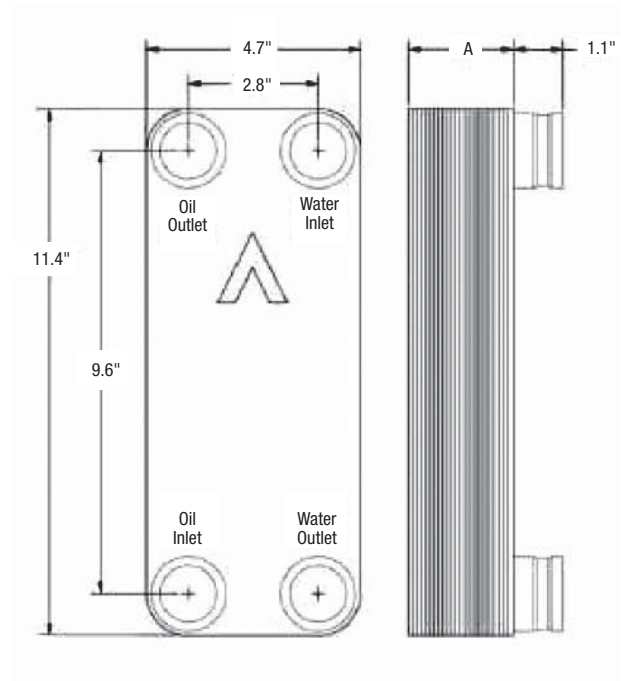
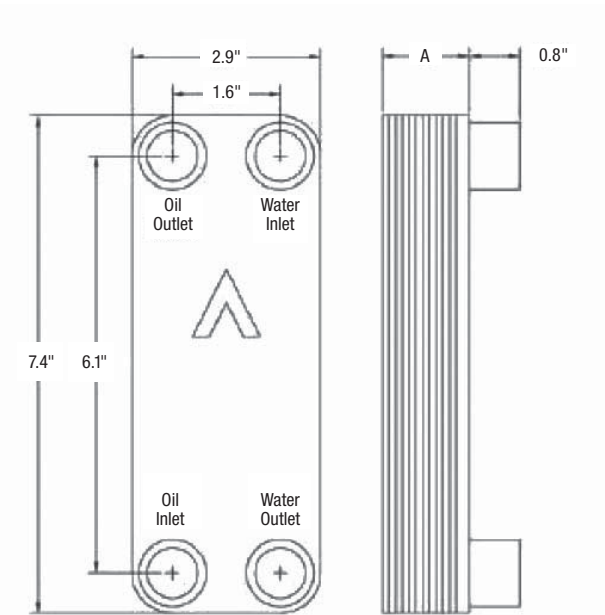
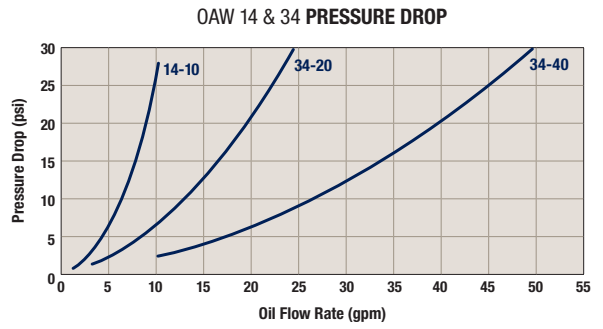
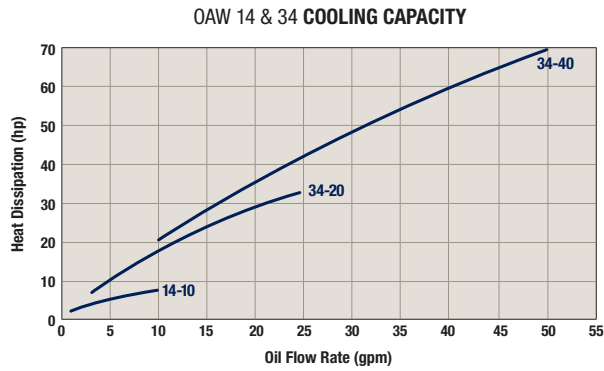

### OAW 46 & OAW 61

MODEL	Cooling Capacity (*hp)	Connection	A (inches)	Weight (lbs.)	Volume (in <sup>3</sup> )
OAW 46-40	21-94	1¼" SAE O-ring	3.9	13	200
OAW 46-60	23-142	1¼" SAE O-ring	5.7	18	300
OAW 61-40	27-98	1¼" SAE O-ring	3.9	19	271
OAW 61-60	53-152	1¼" SAE O-ring	5.7	27	406
OAW 61-80	79-198	1¼" SAE O-ring	7.4	34	542

\*Cooling capacity is calculated with the following conditions. For other flow conditions, type of fluids or temperatures, please see page 35 or consult Accumulator and Cooler Division. Oil type – ISO VG 32 – Oil/water flow ratio – 2:1 – Oil inlet temperature – 140°F – Water inlet temperature – 80°F

OAW 46 & 61 COOLING CAPACITY

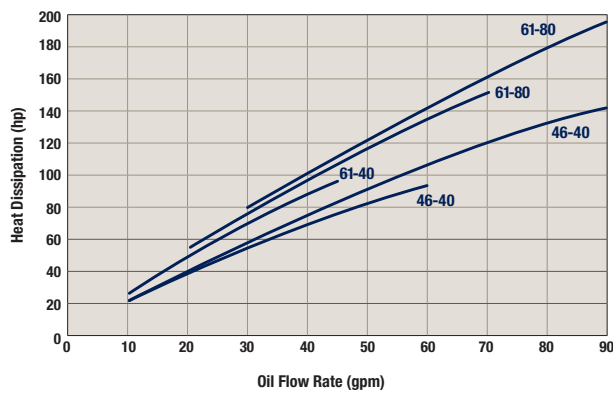

OAW 46 & 61 PRESSURE DROP

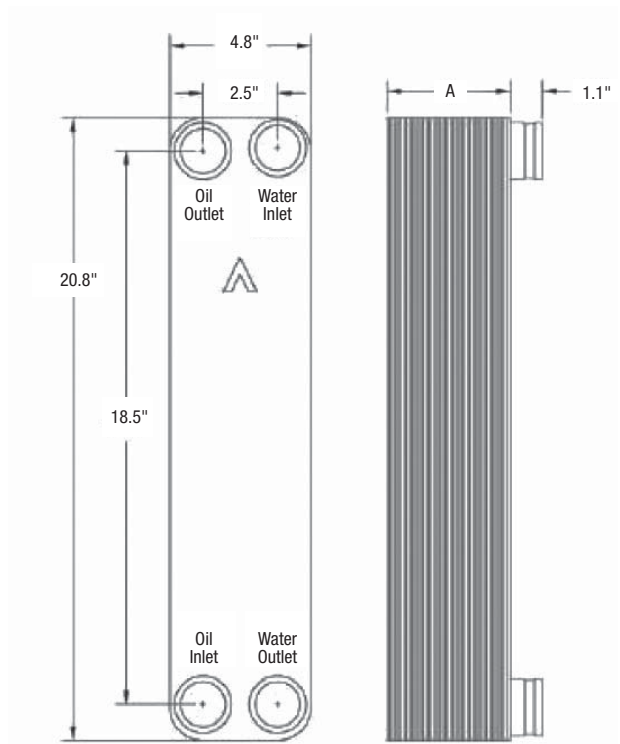
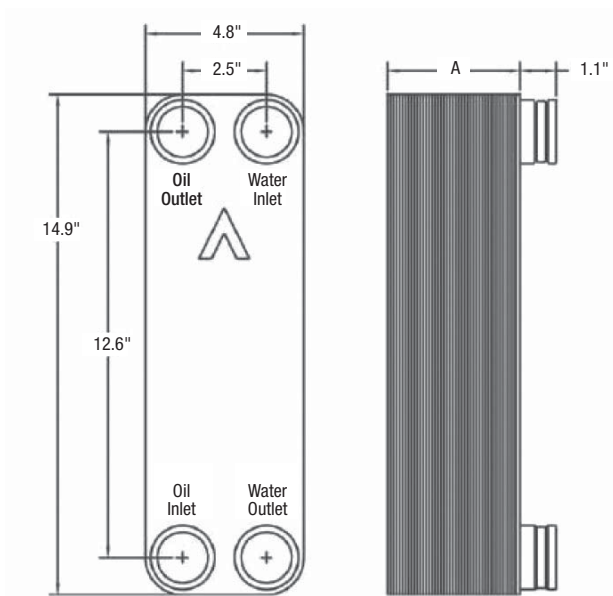
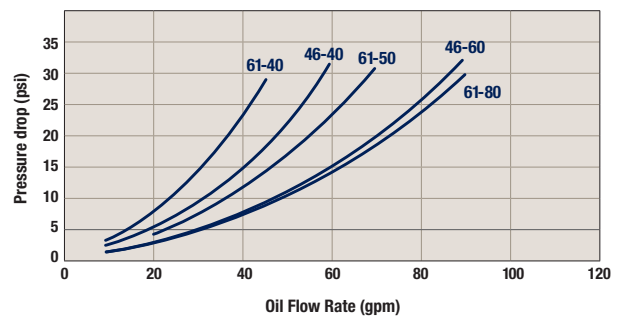

### OAW 95 & OAW 126

MODEL	Cooling Capacity (*hp)	Connection	A (inches)	Weight (lbs.)	Volume (in <sup>3</sup> )
OAW 95-40	50-150	1½" SAE O-ring	4.1	44	427
OAW 95-60	63-171	1½" SAE O-ring	6.0	59	641
OAW 126-60	84-259	1½" SAE O-ring	6.1	79	856
OAW 126-80	138-274	1½" SAE O-ring	7.9	97	1142

\*Cooling capacity is calculated with the following conditions. For other flow conditions, type of fluids or temperatures, please see page 35 or consult Accumulator and Cooler Division. Oil type – ISO VG 32 – Oil/water flow ratio – 2:1 – Oil inlet temperature – 140°F – Water inlet temperature – 80°F

OAW 95 & 126 COOLING CAPACITY

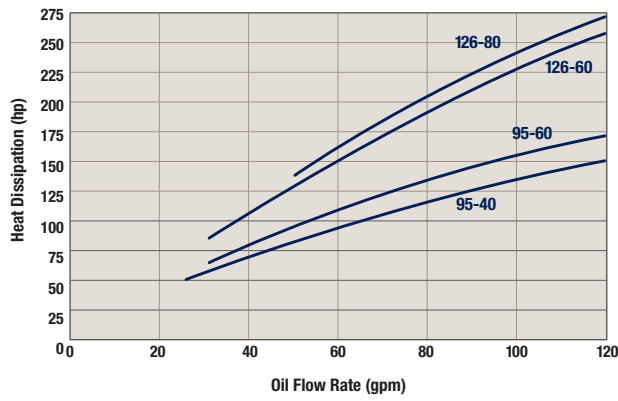

OAW 95 & 126 PRESSURE DROP

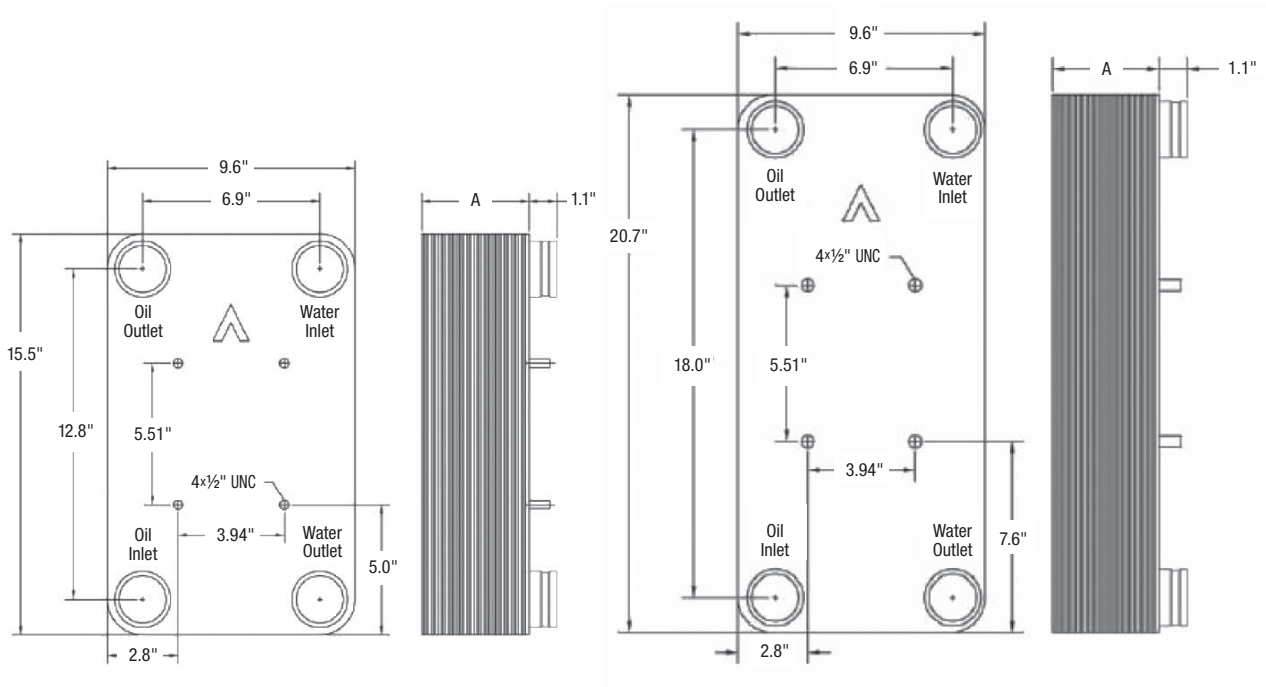
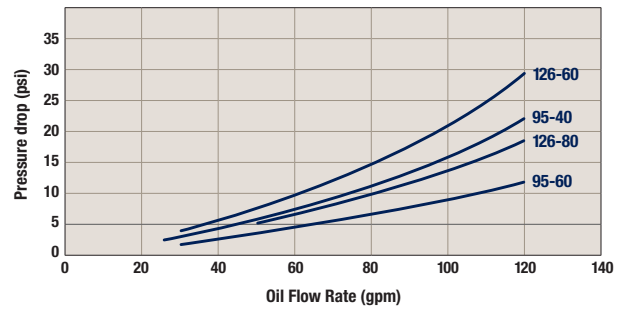

# Installation

## Installation Instructions for OAW Coolers

The OAW coolers are designed for a maximum working pressure of 450 psi. The most standard application for the OAW cooler involves a cold water circuit and a hot oil circuit. Fluids are not limited to oil and water however; for other types of fluid, please contact the factory.

Inlets and outlets are clearly identified by the Accumulator and Cooler Division sticker affixed to the front of the unit. When in doubt, pour a liquid in one of the connections and note which connection it comes out of. This will be the inlet and outlet for one circuit (either oil or water). The other inlet should be located on the diagonal from the first inlet.

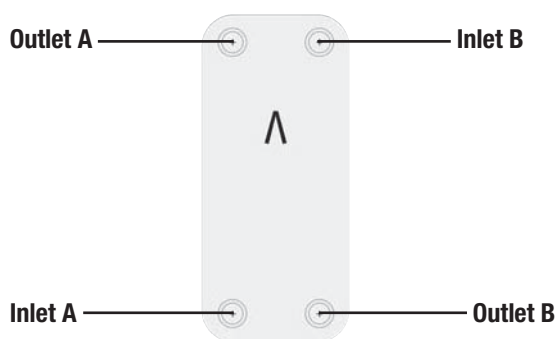

Maximum cooling efficiency is achieved by cross flowing through the plates, the oil inlet and water inlet being located on a diagonal. Failure to have the cooler attached in this manner will lead to a decrease in efficiency.

The cooler may be mounted in any position. However, requirements for draining the circuits should be taken into consideration.

The OAW coolers must not be installed into a rigid frame. Use the Accumulator and Cooler Division purpose-made brackets (or "Armafex" equivalent) to provide a "soft, elastic installation." The OAW 95 and 126 series coolers come equipped with stud bolts to assist in mounting. However, these bolts alone should not be used to suspend the cooler. All tubing should be done in such a way as to minimize vibrations to the cooler. When installed on a return line, the cooler should be connected using flexible hoses.

## When to Clean

Fouling occurs mainly on the water side of the cooler. Fouling can be detected by monitoring the inlet and outlet temperatures and/or the pressure drop across the cooler. Fouling will result in decreased heat transfer, producing temperature differences lower than specified.

Fouling also restricts the passages and thus causes an increase in velocity. This will produce an increase in the pressure drop across the cooler. When either the temperature difference or the pressure drop is significantly different from specified values, cleaning should be performed.

## Methods of Cleaning

If cleaning the cooler is required, backflushing with water will remove most of the soft deposits. If fouling appears in the form of hard deposits, circulate a weak acid through the cooler in reverse direction to normal water flow. Use 5% phosphoric acid for infrequent cleanings. For more frequent cleaning, use 5% oxalic acid or similar weak organic acid. Afterwards flush with a large quantity of water to remove all acid from the cooler before starting up the system again. Never wait until the cooler is completely clogged before cleaning!

## Filters or Strainers

When there are particles in the fluid that could clog the cooler, filters or strainers should be used. Particles up to 1mm diameter will not cause any problems.

## Fluid Compatibility

On the oil side, most synthetic and petroleum based fluids may be used. For aggressive oils, please contact Accumulator and Cooler Division for compatibility. On the water side, de-mineralized and untreated water may be used without concern. When water is chemically treated please contact Accumulator and Cooler Division for suitability. Sea water cannot be used in OAW coolers. For sea water applications, please contact Accumulator and Cooler Division on information on titanium coolers. Do not use ammonia in the OAW coolers.

### Correction Factors for Other Oil Types, Temperatures and Flow Rates

All of the cooling curves are based on very specific conditions. These include using an ISO VG 32 oil, having an oil/water ratio of 2:1, and having an oil/water inlet difference of 60 °F. For other conditions, the following correction factors should be used.

#### Correction Factors for Other Oil Types

*Cooling Capacity:* Multiply the requested cooling capacity with the correction factor Kv.

*Oil Pressure Drop:* Multiply the pressure drop with the correction factor Kp.

Viscosity Class	Cooling Capacity Factor, Kv	Pressure Drop Factor, Kp
ISO VG 22	0.95	0.9
ISO VG 32	1.0	1.0
ISO VG 46	1.05	1.3
ISO VG 68	1.2	1.7
ISO VG 100	1.35	2.2
ISO VG 150	1.6	3.0
ISO VG 220	1.9	4.3

Table 1

#### Correction Factors for Other Inlet Temperature Differences

*Cooling Capacity:* For inlet temperature differences other than 60 °F, multiply the requested cooling capacity by the correction factor Kt.

ETD	30	40	50	60	70
Kt	1.87	1.43	1.17	1.0	0.88

Table 2

#### Correction Curves for Other Oil/Water Flow Ratios

*Cooling Capacity:* For all other oil/water flow ratios other than 2:1, divide the requested cooling capacity by the factor Kr obtained from the curves in Graph 3.

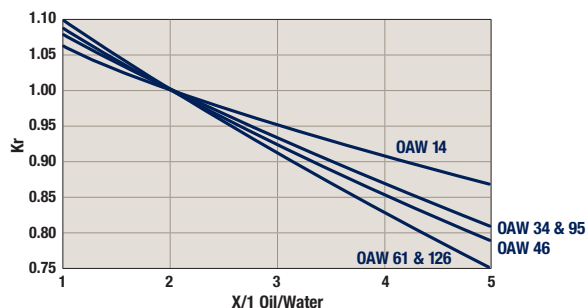

Graph 3

### Sizing Example

Conditions:  
 Oil type: ISO VG 68  
 Oil Flow: 40 gpm  
 Desired cooling capacity Qr 40 hp  
 Oil temperature in To 140 °F  
 Water temperature in Tw 100 °F  
 Available water flow 10 gpm  
 Maximum Pressure Drop 30 psi

$$ETD = To - Tw = 140^{\circ}F - 100^{\circ}F = 40^{\circ}F$$

The design cooling capacity (Qd) is the cooling capacity used when selecting a suitable cooler. Qd is calculated by multiplying Qr by the factors Kv and Kt (found in Tables 1 and 2 respectively) and then dividing by the Kr factor found from Graph 3.

$$Qd = \frac{Qr \times Kv \times Kt}{Kr} = \frac{40 \text{ hp} \times 1.2 \times 1.43}{0.82} = 83 \text{ hp}$$

According to the cooling capacity curves on page 32, the minimum size cooler for these conditions is an OAW 61-40.

The oil pressure drop can be found from the pressure drop curve. It should be multiplied by the Pressure Drop Factor, Kp from Table 1.

$$D_{Poil} = p \times Kp = 23 \text{ psi} \times 1.7 = 39.1 \text{ psi.}$$

In this case the pressure drop exceeds the maximum allowable. The next size cooler would be an: OAW 61-60

The pressure drop for this cooler would be:

$$D_{Poil} = p \times Kp = 12 \text{ psi} \times 1.7 = 20.4 \text{ psi.}$$

Therefore the correct size cooler would be the OAW 61-60.

For assistance with calculations, please contact Accumulator and Cooler Division.





# Take the next step

Choose the right accessories

Supplementing a hydraulic system with a cooler and proper accessories or an accumulator gives you increased system up time and a longer expected life as well as lower service and repair costs. All applications and operating environments

are unique. A well-planned choice of the following accessories can thus further improve your hydraulic system. Please contact Accumulator and Cooler Division for guidance and information.



### Pressure-controlled bypass valve *Integrated*

Allows the oil to bypass the cooler core if the pressure drop is too high. Reduces the risk of the cooler bursting, e.g. in connection with cold starts and temporary peaks in pressure or flow. Available for single-pass or two-pass core design.



### Smart DC Drive speed regulation

For cost-efficient operation and better environmental consideration through speed regulated fan control – the higher the temperature, the higher the fan speed.



### Temperature-controlled bypass valve *Integrated*

Same function as the pressure-controlled by-pass valve, but with a temperature-controlled opening pressure – the hotter the oil, the higher the opening pressure. Available for single-pass or two-pass core design.



### Stone guard/Dust guard

Protects components and systems from tough conditions.



### Thermo contact

Sensor with fixed set point for temperature warnings and cost efficient operation with automatic switching on and off of the fan motor thereby reducing the energy usage.



### Temperature-controlled 3-way valve *External*

Same function as the temperature-controlled bypass valve, but positioned externally.

**Note:** *Must be ordered separately.*



### Lifting eyes

For simple installation and relocation.



Professional competence, as well as advanced technology and extensive knowledge from the industry, allow us to provide many cooler combinations, which meet your unique needs.

## Cooling Modules/ Combination Cooler

Providing optimal solutions

A close collaboration between our application engineers, designers and you as the customer during the whole project will result in a high-quality product. The final product will be a tailor-made cooler, which always meets your unique needs.

### **Extensive choices**

Long-term experience from the mobile field has provided us with a unique ability to deliver the

ideal combination cooler solution. Depending on the conditions, the cooler fan can be operated by the diesel engine on the machine or by a hydraulic motor or a DC motor. We can also supply many different cooler combination options. A frequent combination is the “side-by-side”-cooler, where the coolers are placed side-by-side, no matter the media, such as a water cooler, an oil cooler and an intercooler. Another solution is

the “sandwich”-cooler, where the coolers are placed in front of each other. The solution could also be a combination of these two. No matter which combination will be used, the pressure drop and the heat dissipation across the core will always be optimal.

# Parker's Motion & Control Product Groups

*At Parker, we're guided by a relentless drive to help our customers become more productive and achieve higher levels of profitability by engineering the best systems for their requirements. It means looking at customer applications from many angles to find new ways to create value. Whatever the motion and control technology need, Parker has the experience, breadth of product and global reach to consistently deliver. No company knows more about motion and control technology than Parker. For further info call 1 800 C-Parker (1 800 272 7537)*



## **Aerospace**

### **Key Markets**

Aftermarket services  
Commercial transports  
Engines  
General & business aviation  
Helicopters  
Launch vehicles  
Military aircraft  
Missiles  
Power generation  
Regional transports  
Unmanned aerial vehicles

### **Key Products**

Control systems & actuation products  
Engine systems & components  
Fluid conveyance systems & components  
Fluid metering, delivery & atomization devices  
Fuel systems & components  
Fuel tank inerting systems  
Hydraulic systems & components  
Thermal management  
Wheels & brakes



## **Automation**

### **Key Markets**

Renewable energy  
Conveyor & material handling  
Factory automation  
Food & beverage  
Life sciences & medical  
Machine tools  
Packaging machinery  
Paper machinery  
Plastics machinery  
Primary metals  
Safety & security  
Semiconductor & electronics  
Transportation & automotive

### **Key Products**

AC/DC drives & systems  
Air preparation  
Electric actuators, gantry robots & slides  
Human machine interfaces  
Inverters  
Manifolds  
Miniature fluidics  
Pneumatic actuators & grippers  
Pneumatic valves & controls  
Rotary actuators  
Stepper motors, servo motors, drives & controls  
Structural extrusions  
Vacuum generators, cups & sensors



## **Climate & Industrial Controls**

### **Key Markets**

Agriculture  
Air conditioning  
Construction Machinery  
Food & beverage  
Industrial machinery  
Life sciences  
Oil & gas  
Power Generation  
Process  
Refrigeration  
Transportation

### **Key Products**

Accumulators  
Advanced actuators  
CO<sub>2</sub> controls  
Electronic controllers  
Filter driers  
Hand shut-off valves  
Heat exchangers  
Hose & fittings  
Pressure regulating valves  
Refrigerant distributors  
Safety relief valves  
Smart pumps  
Solenoid valves  
Thermal management systems  
Thermostatic expansion valves



## **Filtration**

### **Key Markets**

Aerospace  
Food & beverage  
Industrial plant & equipment  
Life sciences  
Marine  
Mobile equipment  
Oil & gas  
Power generation  
Process  
Transportation  
Water Purification

### **Key Products**

Analytical gas generators  
Compressed air filters & dryers  
Engine air, coolant, fuel & oil filtration systems  
Fluid condition monitoring systems  
Hydraulic & lubrication filters  
Hydrogen, nitrogen & zero air generators  
Instrumentation filters  
Membrane & fiber filters  
Microfiltration  
Sterile air filtration  
Water desalination & purification filters & systems



## **Fluid Connectors**

### **Key Markets**

Aerial lift  
Agriculture  
Bulk chemical handling  
Construction machinery  
Food & beverage  
Fuel & gas delivery  
Industrial machinery  
Life sciences  
Marine  
Mining  
Mobile  
Oil & gas  
Renewable energy  
Transportation

### **Key Products**

Check valves  
Connectors for low pressure fluid conveyance  
Deep sea umbilicals  
Diagnostic equipment  
Hose couplings  
Industrial hose  
Mooring systems & power cables  
PTFE hose & tubing  
Quick couplings  
Rubber & thermoplastic hose  
Tube fittings & adapters  
Tubing & plastic fittings



## **Hydraulics**

### **Key Markets**

Aerial lift  
Agriculture  
Alternative energy  
Construction machinery  
Forestry  
Industrial machinery  
Machine tools  
Marine  
Material handling  
Mining  
Oil & gas  
Power generation  
Refuse vehicles  
Renewable energy  
Truck hydraulics  
Turf equipment

### **Key Products**

Accumulators  
Cartridge valves  
Electrohydraulic actuators  
Human machine interfaces  
Hybrid drives  
Hydraulic cylinders  
Hydraulic motors & pumps  
Hydraulic systems  
Hydraulic valves & controls  
Hydrostatic steering  
Integrated hydraulic circuits  
Power take-offs  
Power units  
Rotary actuators  
Sensors



## **Instrumentation**

### **Key Markets**

Alternative fuels  
Biopharmaceuticals  
Chemical & refining  
Food & beverage  
Marine & shipbuilding  
Medical & dental  
Microelectronics  
Nuclear Power  
Offshore oil exploration  
Oil & gas  
Pharmaceuticals  
Power generation  
Pulp & paper  
Steel  
Water/wastewater

### **Key Products**

Analytical Instruments  
Analytical sample conditioning products & systems  
Chemical injection fittings & valves  
Fluoropolymer chemical delivery fittings, valves & pumps  
High purity gas delivery fittings, valves, regulators & digital flow controllers  
Industrial mass flow meters/controllers  
Permanent no-weld tube fittings  
Precision industrial regulators & flow controllers  
Process control double block & bleeds  
Process control fittings, valves, regulators & manifold valves



## **Seal**

### **Key Markets**

Aerospace  
Chemical processing  
Consumer  
Fluid power  
General industrial  
Information technology  
Life sciences  
Microelectronics  
Military  
Oil & gas  
Power generation  
Renewable energy  
Telecommunications  
Transportation

### **Key Products**

Dynamic seals  
Elastomeric o-rings  
Electro-medical instrument design & assembly  
EMI shielding  
Extruded & precision-cut, fabricated elastomeric seals  
High temperature metal seals  
Homogeneous & inserted elastomeric shapes  
Medical device fabrication & assembly  
Metal & plastic retained composite seals  
Shielded optical windows  
Silicone tubing & extrusions  
Thermal management  
Vibration dampening



ENGINEERING YOUR SUCCESS.



Parker Hannifin Corporation  
**Accumulator & Cooler Division - Americas**  
10711 N Second Street  
Rockford, IL 61115  
phone 815 636 4100  
fax 815 636 4111  
[www.parker.com](http://www.parker.com)